



An Oshkosh Corporation Company

Operation and Safety Manual

Original Instructions - Keep this manual with the machine at all times.

Boom Lift Models

1200SJP

1350SJP

ANSI



3121141

September 11, 2014

FOREWORD

This manual is a very important tool! Keep it with the machine at all times.

The purpose of this manual is to provide owners, users, operators, lessors, and lessees with the precautions and operating procedures essential for the safe and proper machine operation for its intended purpose.

Due to continuous product improvements, JLG Industries, Inc. reserves the right to make specification changes without prior notification. Contact JLG Industries, Inc. for updated information.

SAFETY ALERT SYMBOLS AND SAFETY SIGNAL WORDS



This is the Safety Alert Symbol. It is used to alert you to the potential personal injury hazards. Obey all safety messages that follow this symbol to avoid possible injury or death

⚠ DANGER

INDICATES AN IMMINENTLY HAZARDOUS SITUATION. IF NOT AVOIDED, WILL RESULT IN SERIOUS INJURY OR DEATH. THIS DECAL WILL HAVE A RED BACKGROUND.

⚠ WARNING

INDICATES A POTENTIALLY HAZARDOUS SITUATION. IF NOT AVOIDED, MAY RESULT IN SERIOUS INJURY OR DEATH. THIS DECAL WILL HAVE AN ORANGE BACKGROUND.

⚠ CAUTION

INDICATES A POTENTIALLY HAZARDOUS SITUATION. IF NOT AVOIDED, MAY RESULT IN MINOR OR MODERATE INJURY. IT MAY ALSO ALERT AGAINST UNSAFE PRACTICES. THIS DECAL WILL HAVE A YELLOW BACKGROUND.

NOTICE

INDICATES INFORMATION OR A COMPANY POLICY THAT RELATES DIRECTLY OR INDIRECTLY TO THE SAFETY OF PERSONNEL OR PROTECTION OF PROPERTY.

⚠ WARNING

THIS PRODUCT MUST COMPLY WITH ALL SAFETY RELATED BULLETINS. CONTACT JLG INDUSTRIES, INC. OR THE LOCAL AUTHORIZED JLG REPRESENTATIVE FOR INFORMATION REGARDING SAFETY-RELATED BULLETINS WHICH MAY HAVE BEEN ISSUED FOR THIS PRODUCT.

NOTICE

JLG INDUSTRIES, INC. SENDS SAFETY RELATED BULLETINS TO THE OWNER OF RECORD OF THIS MACHINE. CONTACT JLG INDUSTRIES, INC. TO ENSURE THAT THE CURRENT OWNER RECORDS ARE UPDATED AND ACCURATE.

NOTICE

JLG INDUSTRIES, INC. MUST BE NOTIFIED IMMEDIATELY IN ALL INSTANCES WHERE JLG PRODUCTS HAVE BEEN INVOLVED IN AN ACCIDENT INVOLVING BODILY INJURY OR DEATH OF PERSONNEL OR WHEN SUBSTANTIAL DAMAGE HAS OCCURRED TO PERSONAL PROPERTY OR THE JLG PRODUCT.

For:

- Accident Reporting
- Product Safety Publications
- Current Owner Updates
- Questions Regarding Product Safety
- Standards and Regulations Compliance Information
- Questions Regarding Special Product Applications
- Questions Regarding Product Modifications

Contact:

Product Safety and Reliability Department
JLG Industries, Inc.
13224 Fountainhead Plaza
Hagerstown, MD 21742
USA

or Your Local JLG Office
(See addresses on inside of manual cover)

In USA:

Toll Free: 877-JLG-SAFE (877-554-7233)

Outside USA:

Phone: 240-420-2661
Fax: 301-745-3713
E-mail: ProductSafety@JLG.com

REVISION LOG

Original Issue	- May 24, 2002	Revised	- October 7, 2013
Revised	- June 14, 2002	Revised	- September 11, 2014
Revised	- November 1, 2002		
Revised	- January 15, 2003		
Revised	- May 3, 2005		
Revised	- August 30, 2005		
Revised	- January 12, 2006		
Revised	- June 19, 2006		
Revised	- July 17, 2006		
Revised	- December 1, 2006		
Revised	- April 11, 2007		
Revised	- June 19, 2008		
Revised	- November 19, 2009		
Revised	- August 30, 2010		
Revised	- November 3, 2010		
Revised	- June 2, 2011		
Revised	- September 20, 2012		

SECTION - PARAGRAPH, SUBJECT	PAGE
SECTION - 1 - SAFETY PRECAUTIONS	
1.1 GENERAL	1-1
1.2 PRE-OPERATION	1-1
Operator Training and Knowledge	1-1
Workplace Inspection	1-2
Machine Inspection	1-3
1.3 OPERATION	1-3
General	1-3
Trip and Fall Hazards	1-4
Electrocution Hazards	1-5
Tipping Hazards	1-7
Crushing and Collision Hazards	1-10
1.4 TOWING, LIFTING, AND HAULING	1-11
1.5 MAINTENANCE	1-11
Maintenance Hazards	1-11
Battery Hazards	1-13
SECTION - 2 - USER RESPONSIBILITIES, MACHINE PREPARATION, AND INSPECTION	
2.1 PERSONNEL TRAINING	2-1
Operator Training	2-1
Training Supervision	2-1
Operator Responsibility	2-1
2.2 PREPARATION, INSPECTION, AND MAINTENANCE	2-2
Pre-Start Inspection	2-4
Function Check	2-5

SECTION - PARAGRAPH, SUBJECT	PAGE
Boom Control System Check Procedure	2-6
General	2-9
2.3 OSCILLATING AXLE LOCKOUT TEST (IF EQUIPPED)	2-11
SECTION - 3 - MACHINE CONTROLS AND INDICATORS	
3.1 GENERAL	3-1
3.2 CONTROLS AND INDICATORS	3-1
Ground Control Station	3-1
Ground Control Indicator Panel	3-5
Platform Station	3-6
Platform Control Indicator Panel	3-15
SECTION - 4 - MACHINE OPERATION	
4.1 DESCRIPTION	4-1
4.2 BOOM OPERATING CHARACTERISTICS AND LIMITATIONS	4-1
Capacities	4-1
Controlled Arc	4-2
Envelope Tracking	4-3
Controlled Angle	4-3
Swing Speed Proportioning	4-3
Stability	4-4
4.3 CAPACITY SELECT	4-4
4.4 ENGINE OPERATION	4-5
Starting Procedure	4-5
Shutdown Procedure	4-5

TABLE OF CONTENTS

SECTION - PARAGRAPH, SUBJECT	PAGE	SECTION - PARAGRAPH, SUBJECT	PAGE
		SECTION - 5 - EMERGENCY PROCEDURES	
		5.1 GENERAL	5-1
		5.2 INCIDENT NOTIFICATION	5-1
		5.3 EMERGENCY OPERATION	5-1
		Operator Unable to Control Machine	5-1
		Platform or Boom Caught Overhead	5-2
		Boom Movement Prevented By Boom Control System	5-2
		5.4 EMERGENCY TOWING PROCEDURES	5-2
		SECTION - 6 - GENERAL SPECIFICATIONS & OPERATOR MAINTENANCE	
		6.1 INTRODUCTION	6-1
		6.2 OPERATING SPECIFICATIONS	6-1
		Dimensional Data	6-2
		Chassis	6-3
		Capacities	6-3
		Tires	6-4
4.5 FUEL RESERVE / SHUT-OFF SYSTEM	4-6		
4.5 TRAVELING (DRIVING)	4-8		
Traveling Forward and Reverse	4-9		
4.6 STEERING	4-9		
4.7 EXTENDING THE AXLES	4-9		
4.8 PLATFORM	4-11		
Platform Level Adjustment	4-11		
Platform Rotation	4-11		
4.9 BOOM	4-11		
Swinging the Boom	4-12		
Raising and Lowering the Boom	4-12		
Telescoping the Boom	4-12		
Swinging the Jib	4-12		
4.10 FUNCTION SPEED CONTROL	4-12		
4.11 EMERGENCY TOWING	4-13		
4.12 SHUT DOWN AND PARK	4-14		
4.13 LIFTING AND TIE DOWN	4-14		
Lifting	4-14		
Tie Down	4-15		
4.14 STOWING THE JIB FOR TRANSPORT	4-15		

SECTION - PARAGRAPH, SUBJECT	PAGE	SECTION - PARAGRAPH, SUBJECT	PAGE
Engine Data - Deutz 2011 Prior to S/N 0300127698	6-4		
Engine Data - Deutz 2011 S/N 0300127698 to Present	6-5		
Engine Data - Caterpillar	6-6		
Hydraulic Oil	6-6		
Major Component Weights	6-10		
6.3 OPERATOR MAINTENANCE	6-16		
6.4 TIRES & WHEELS.....	6-28		
Tire Inflation.....	6-28		
Tire Damage.....	6-28		
Tire Replacement.....	6-28		
Wheel Replacement	6-29		
Wheel Installation	6-29		
6.5 SUPPLEMENTAL INFORMATION	6-30		

SECTION - 7 - INSPECTION AND REPAIR LOG

TABLE OF CONTENTS

SECTION - PARAGRAPH, SUBJECT

PAGE

SECTION - PARAGRAPH, SUBJECT

PAGE

This Page Left Blank Intentionally.

FIGURE NUMBER - TITLE	PAGE
2-1. Basic Nomenclature.....	2-7
2-2. Daily Walk-Around Inspection - Sheet 1 of 3	2-8
2-3. Daily Walk-Around Inspection - Sheet 2 of 3	2-9
2-4. Daily Walk-Around Inspection - Sheet 3 of 3	2-10
3-1. Ground Control Station	3-2
3-2. Ground Control Indicator Panel	3-5
3-3. Platform Control Console - Prior to S/N 79596.....	3-8
3-4. Platform Control Console - S/N 79596 to 93078	3-9
3-5. Platform Control Console - w/Boom Control Select... 3-10	
3-6. Platform Control Indicator Panel - Prior to S/N 79596	3-16
3-7. Platform Control Indicator Panel - S/N 79596 to Present	3-17
3-8. Fuel Level Indicator	3-19
4-1. Position of Least Forward Stability.....	4-7
4-2. Position of Least Backward Stability	4-8
4-3. Grade and Side Slopes	4-10
4-4. Drive Disconnect Hub.....	4-13
4-5. Lifting and Tie Down Chart - Sheet 1 of 2	4-16
4-6. Lifting and Tie Down Chart - Sheet 2 of 2	4-17
4-7. Decal Location Sheet 1 of 5.....	4-18
4-8. Decal Location Sheet 2 of 5.....	4-19
4-9. Decal Location Sheet 3 of 5.....	4-20
4-10. Decal Location Sheet 4 of 5.....	4-21
4-11. Decal Location Sheet 5 of 5.....	4-22

FIGURE NUMBER - TITLE	PAGE
6-1. Engine Operating Temperature Specifications - Deutz - Sheet 1 of 2	6-11
6-2. Engine Operating Temperature Specifications - Deutz - Sheet 2 of 2	6-12
6-3. Engine Operating Temperature Specifications - Caterpillar - Sheet 1 of 2	6-13
6-4. Engine Operating Temperature Specifications - Caterpillar - Sheet 2 of 2	6-14
6-5. Lubrication and Maintenance Point Location	6-15
6-6. Deutz 2011 Engine Dipstick	6-22

LIST OF FIGURES

FIGURE NUMBER - TITLE

PAGE

FIGURE NUMBER - TITLE

PAGE

This Page Left Blank Intentionally.

TABLE NUMBER - TITLE	PAGE	TABLE NUMBER - TITLE	PAGE
1-1	Minimum Approach Distances (M.A.D.)	1-6	
1-2	Beaufort Scale (For Reference Only).....	1-9	
2-1	Inspection and Maintenance Table	2-3	
4-1	Decal Legend - Prior to S/N 0300141473	4-23	
4-2	Decal Legend - S/N 0300141473 to Present	4-27	
6-1	Operating Specifications - Prior to S/N 0300141473 ...	6-1	
6-2	Operating Specifications - S/N 0300141473 to Present.....	6-2	
6-3	Dimensional Data	6-2	
6-4	Chassis Specifications	6-3	
6-5	Capacities	6-3	
6-6	Tire Specifications.....	6-4	
6-7	Deutz BF4M2011 Specifications	6-4	
6-8	Deutz TD2011L4 Specifications.....	6-5	
6-9	Deutz TCD2.9L4 Specifications	6-5	
6-10	Caterpillar 3.4T Specifications	6-6	
6-11	Hydraulic Oil Specifications.....	6-6	
6-12	Mobilfluid 424 Specs.....	6-7	
6-13	Mobil DTE 13M Specs	6-7	
6-14	UCon Hydrolube HP-5046	6-8	
6-15	Mobil EAL H 46 Specs	6-8	
6-16	Exxon Univis HVI 26 Specs.....	6-9	
6-17	Component Weights.....	6-10	
6-18	Lubrication Specifications.....	6-16	
6-19	Wheel Torque Chart.....	6-30	
7-1	Inspection and Repair Log.....	7-1	

LIST OF TABLES

TABLE NUMBER - TITLE

PAGE

TABLE NUMBER - TITLE

PAGE

This Page Left Blank Intentionally.

SECTION 1. SAFETY PRECAUTIONS

1.1 GENERAL

This section outlines the necessary precautions for proper and safe machine usage and maintenance. It is mandatory that a daily routine is established based on the content of this manual to promote proper machine usage. A maintenance program, using the information provided in this manual and the Service and Maintenance Manual, must also be established by a qualified person and must be followed to ensure that the machine is safe to operate.

The owner/user/operator/lessor/lessee of the machine must not accept operating responsibility until this manual has been read, training is accomplished, and operation of the machine has been completed under the supervision of an experienced and qualified operator.

This section contains the responsibilities of the owner, user, operator, lessor, and lessee concerning safety, training, inspection, maintenance, application, and operation. If there are any questions with regard to safety, training, inspection, maintenance, application, and operation, please contact JLG Industries, Inc. ("JLG").

WARNING

FAILURE TO COMPLY WITH THE SAFETY PRECAUTIONS LISTED IN THIS MANUAL COULD RESULT IN MACHINE DAMAGE, PROPERTY DAMAGE, PERSONAL INJURY OR DEATH.

1.2 PRE-OPERATION

Operator Training and Knowledge

- The Operation and Safety Manual must be read and understood in its entirety before operating the machine. For clarification, questions, or additional information regarding any portions of this manual, contact JLG Industries, Inc.

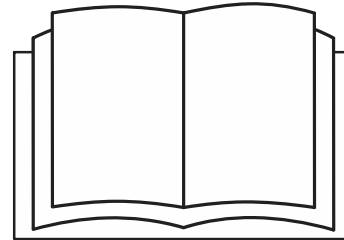

SECTION 1 - SAFETY PRECAUTIONS

- An operator must not accept operating responsibilities until adequate training has been given by competent and authorized persons.
- Allow only those authorized and qualified personnel to operate the machine who have demonstrated that they understand the safe and proper operation and maintenance of the unit.
- Read, understand, and obey all DANGERS, WARNINGS, CAUTIONS, and operating instructions on the machine and in this manual.
- Ensure that the machine is to be used in a manner which is within the scope of its intended application as determined by JLG.
- All operating personnel must be familiar with the emergency controls and emergency operation of the machine as specified in this manual.
- Read, understand, and obey all applicable employer, local, and governmental regulations as they pertain to your utilization and application of the machine.

Workplace Inspection

- Precautions to avoid all hazards in the work area must be taken by the user before and during operation of the machine.
- Do not operate or raise the platform from a position on trucks, trailers, railway cars, floating vessels, scaffolds or other equipment unless the application is approved in writing by JLG.
- Before operation, check work area for overhead hazards such as electric lines, bridge cranes, and other potential overhead obstructions.
- Check operating surfaces for holes, bumps, drop-offs, obstructions, debris, concealed holes, and other potential hazards.
- Check the work area for hazardous locations. Do not operate the machine in hazardous environments unless approved for that purpose by JLG.
- Ensure that the ground conditions are adequate to support the maximum tire load indicated on the tire load decals located on the chassis adjacent to each wheel. Do not travel on unsupported surfaces.

Machine Inspection

- Do not operate this machine until the inspections and functional checks as specified in Section 2 of this manual have been performed.
- Do not operate this machine until it has been serviced and maintained according to the maintenance and inspection requirements as specified in the machine's Service and Maintenance Manual.
- Ensure all safety devices are operating properly. Modification of these devices is a safety violation.

WARNING

MODIFICATION OR ALTERATION OF AN AERIAL WORK PLATFORM SHALL BE MADE ONLY WITH PRIOR WRITTEN PERMISSION FROM THE MANUFACTURER.

- Do not operate any machine on which the safety or instruction placards or decals are missing or illegible.
- Check the machine for modifications to original components. Ensure that any modifications have been approved by JLG.
- Avoid accumulation of debris on platform floor. Keep mud, oil, grease, and other slippery substances from footwear and platform floor.

1.3 OPERATION

General

- Machine operation requires your full attention. Bring the machine to a full stop before using any device, i.e. cell phones, two-way radios, etc. that will distract your attention from safely operating the machine.
- Do not use the machine for any purpose other than positioning personnel, their tools, and equipment.
- Before operation, the user must be familiar with the machine capabilities and operating characteristics of all functions.
- Never operate a malfunctioning machine. If a malfunction occurs, shut down the machine. Remove the unit from service and notify the proper authorities.
- Do not remove, modify, or disable any safety devices.
- Never slam a control switch or lever through neutral to an opposite direction. Always return switch to neutral and stop before moving the switch to the next function. Operate controls with slow and even pressure.
- Do not allow personnel to tamper with or operate the machine from the ground with personnel in the platform, except in an emergency.

SECTION 1 - SAFETY PRECAUTIONS

- Do not carry materials directly on platform railing unless approved by JLG.
- When two or more persons are in the platform, the operator shall be responsible for all machine operations.
- Always ensure that power tools are properly stowed and never left hanging by their cord from the platform work area.
- When driving, always position boom over rear axle in line with the direction of travel. Remember, if boom is over the front axle, steer and drive functions will be reversed.
- Do not assist a stuck or disabled machine by pushing or pulling except by pulling at the chassis tie-down lugs.
- Fully lower platform and shut off all power before leaving machine.
- Remove all rings, watches, and jewelry when operating machine. Do not wear loose fitting clothing or long hair unrestrained which may become caught or entangled in equipment.
- Persons under the influence of drugs or alcohol or who are subject to seizures, dizziness or loss of physical control must not operate this machine.

Trip and Fall Hazards

- During operation, occupants in the platform must wear a full body harness with a lanyard attached to an authorized lanyard anchorage point. Attach only one (1) lanyard per lanyard anchorage point..

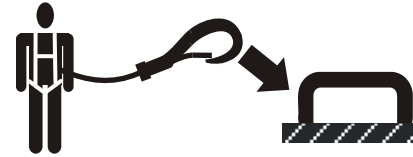

- Enter and exit only through gate area. Use extreme caution when entering or leaving platform. Ensure that the platform assembly is fully lowered. Face the machine when entering or leaving the platform. Always maintain “three point contact” with the machine, using two hands and one foot or two feet and one hand at all times during entry and exit.

- Before operating the machine, make sure all gates are closed and fastened in their proper position.

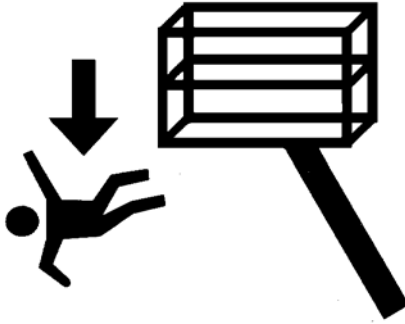

- Keep both feet firmly positioned on the platform floor at all times. Never position ladders, boxes, steps, planks, or similar items on unit to provide additional reach for any purpose.
- Keep oil, mud, and slippery substances cleaned from footwear and the platform floor.

Electrocution Hazards

- This machine is not insulated and does not provide protection from contact or proximity to electrical current.

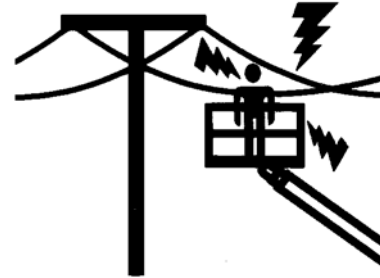

SECTION 1 - SAFETY PRECAUTIONS

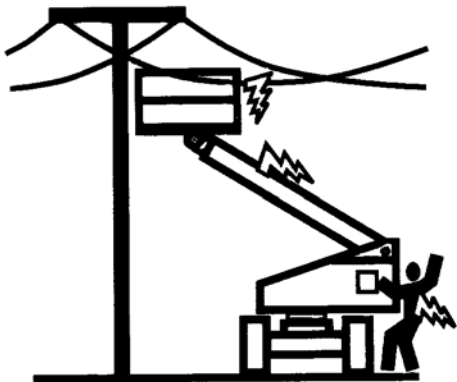

- Maintain distance from electrical lines, apparatus, or any energized (exposed or insulated) parts according to the Minimum Approach Distance (MAD) as shown in Table 1-1.
- Allow for machine movement and electrical line swaying.

Table 1-1. Minimum Approach Distances (M.A.D.)

Voltage Range (Phase to Phase)	MINIMUM APPROACH DISTANCE in Feet (Meters)
0 to 50 KV	10 (3)
Over 50KV to 200 KV	15 (5)
Over 200 KV to 350 KV	20 (6)
Over 350 KV to 500 KV	25 (8)
Over 500 KV to 750 KV	35 (11)
Over 750 KV to 1000 KV	45 (14)

NOTE: *This requirement shall apply except where employer, local or governmental regulations are more stringent.*

- Maintain a clearance of at least 10 ft. (3m) between any part of the machine and its occupants, their tools, and their equipment from any electrical line or apparatus carrying up to 50,000 volts. One foot additional clearance is required for every additional 30,000 volts or less.

- The minimum approach distance may be reduced if insulating barriers are installed to prevent contact, and the barriers are rated for the voltage of the line being guarded. These barriers shall not be part of (or attached to) the machine. The minimum approach distance shall be reduced to a distance within the designed working dimensions of the insulating barrier. This determination shall be made by a qualified person in accordance with the employer, local, or governmental requirements for work practices near energized equipment

⚠ DANGER

DO NOT MANEUVER MACHINE OR PERSONNEL INSIDE PROHIBITED ZONE (MAD). ASSUME ALL ELECTRICAL PARTS AND WIRING ARE ENERGIZED UNLESS KNOWN OTHERWISE.

Tipping Hazards

- The user must be familiar with the surface before driving. Do not exceed the allowable sideslope and grade while driving.

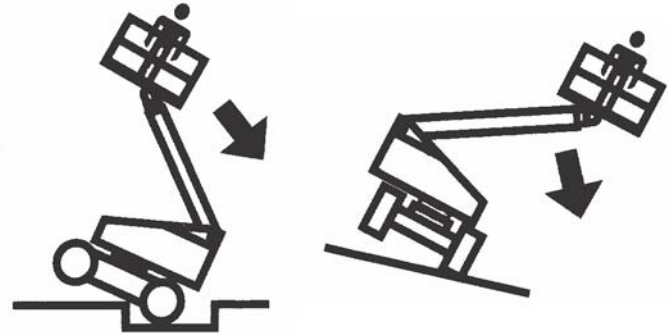

- Do not elevate platform or drive with platform elevated while on or near a sloping, uneven, or soft surface. Ensure machine is positioned on a firm, level and smooth surface before elevating platform or driving with the platform in the elevated position.
- Before driving on floors, bridges, trucks, and other surfaces, check allowable capacity of the surfaces.

SECTION 1 - SAFETY PRECAUTIONS

- Never exceed the maximum work load as specified on the platform. Keep all loads within the confines of the platform, unless authorized by JLG.
- Keep the chassis of the machine a minimum of 2 ft. (0.6m) from holes, bumps, drop-offs, obstructions, debris, concealed holes, and other potential hazards at the ground level.
- Do not push or pull any object with the boom.
- Never attempt to use the machine as a crane. Do not tie-off machine to any adjacent structure. Never attach wire, cable, or any similar items to platform.
- Do not operate the machine when wind conditions exceed 28 mph (12.5 m/s). Refer to Table 1-2, Beaufort Scale (For Reference Only).
- Do not increase the surface area of the platform or the load. Increase of the area exposed to the wind will decrease stability.
- Do not increase the platform size with unauthorized deck extensions or attachments.
- If boom assembly or platform is in a position that one or more wheels are off the ground, all persons must be removed before attempting to stabilize the machine. Use cranes, forklift trucks, or other appropriate equipment to stabilize machine.

NOTICE

DO NOT OPERATE THE MACHINE WHEN WIND CONDITIONS EXCEED 28 MPH (12.5 M/S).

Table 1-2. Beaufort Scale (For Reference Only)

Beaufort Number	Wind Speed		Description	Land Conditions
	mph	m/s		
0	0	0-0.2	Calm	Calm. Smoke rises vertically
1	1-3	0.3-1.5	Light air	Wind motion visible in smoke
2	4-7	1.6-3.3	Light breeze	Wind felt on exposed skin. Leaves rustle
3	8-12	3.4-5.4	Gentle breeze	Leaves and smaller twigs in constant motion
4	13-18	5.5-7.9	Moderate breeze	Dust and loose paper raised. Small branches begin to move.
5	19-24	8.0-10.7	Fresh breeze	Smaller trees sway.
6	25-31	10.8-13.8	Strong breeze	Large branches in motion. Flags waving near horizontal. Umbrella use becomes difficult.
7	32-38	13.9-17.1	Near Gale/Moderate Gale	Whole trees in motion. Effort needed to walk against the wind.
8	39-46	17.2-20.7	Fresh Gale	Twigs broken from trees. Cars veer on road.
9	47-54	20.8-24.4	Strong Gale	Light structure damage.

Crushing and Collision Hazards

- Approved head gear must be worn by all operating and ground personnel.
- Check work area for clearances overhead, on sides, and bottom of platform when lifting or lowering platform, and driving.

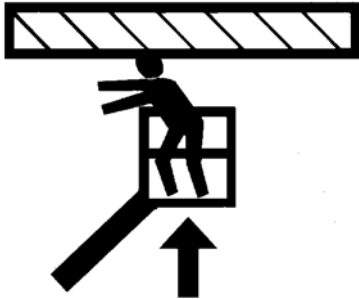

- During operation, keep all body parts inside platform railing.
- Use the boom functions, not the drive function, to position the platform close to obstacles.
- Always post a lookout when driving in areas where vision is obstructed.

- Keep non-operating personnel at least 6 ft. (1.8m) away from machine during all driving and swing operations.
- Under all travel conditions, the operator must limit travel speed according to conditions of ground surface, congestion, visibility, slope, location of personnel, and other factors which may cause collision or injury to personnel.
- Be aware of stopping distances in all drive speeds. When driving in high speed, switch to low speed before stopping. Travel grades in low speed only.
- Do not use high speed drive in restricted or close quarters or when driving in reverse.
- Exercise extreme caution at all times to prevent obstacles from striking or interfering with operating controls and persons in the platform.
- Be sure that operators of other overhead and floor level machines are aware of the aerial work platform's presence. Disconnect power to overhead cranes.
- Warn personnel not to work, stand, or walk under a raised boom or platform. Position barricades on floor if necessary.

1.4 TOWING, LIFTING, AND HAULING

- Never allow personnel in platform while towing, lifting, or hauling.
- This machine should not be towed, except in the event of emergency, malfunction, power failure, or loading/unloading. Refer to the Emergency Procedures section of this manual for emergency towing procedures.
- Ensure boom is in the stowed position and the turntable locked prior to towing, lifting or hauling. The platform must be completely empty of tools.
- When lifting machine, lift only at designated areas of the machine. Lift the unit with equipment of adequate capacity.
- Refer to the Machine Operation section of this manual for lifting information.

1.5 MAINTENANCE

This sub-section contains general safety precautions which must be observed during maintenance of this machine. Additional precautions to be observed during machine maintenance are inserted at the appropriate points in this manual and in the Service and Maintenance Manual. It is of utmost importance that maintenance personnel pay strict attention to these precautions to avoid possible injury to personnel or damage to the machine or property. A maintenance program must be established by a qualified person and must be followed to ensure that the machine is safe.

Maintenance Hazards

- Shut off power to all controls and ensure that all moving parts are secured from inadvertent motion prior to performing any adjustments or repairs.
- Never work under an elevated platform until it has been fully lowered to the full down position, if possible, or otherwise supported and restrained from movement with appropriate safety props, blocking, or overhead supports.
- DO NOT attempt to repair or tighten any hydraulic hoses or fittings while the machine is powered on or when the hydraulic system is under pressure.
- Always relieve hydraulic pressure from all hydraulic circuits before loosening or removing hydraulic components.

SECTION 1 - SAFETY PRECAUTIONS

- DO NOT use your hand to check for leaks. Use a piece of cardboard or paper to search for leaks. Wear gloves to help protect hands from spraying fluid.



- Ensure replacement parts or components are identical or equivalent to original parts or components.
- Never attempt to move heavy parts without the aid of a mechanical device. Do not allow heavy objects to rest in an unstable position. Ensure adequate support is provided when raising components of the machine.

- Do not use machine as a ground for welding.
- When performing welding or metal cutting operations, precautions must be taken to protect the chassis from direct exposure to weld and metal cutting spatter.
- Do not refuel the machine with the engine running.
- Use only approved non-flammable cleaning solvents.
- Do not replace items critical to stability, such as batteries or solid tires, with items of different weight or specification. Do not modify unit in any way to affect stability.
- Refer to the Service and Maintenance Manual for the weights of critical stability items.

⚠ WARNING

MODIFICATION OR ALTERATION OF AN AERIAL WORK PLATFORM SHALL BE MADE ONLY WITH PRIOR WRITTEN PERMISSION FROM THE MANUFACTURER.

Battery Hazards

- Always disconnect batteries when servicing electrical components or when performing welding on the machine.
- Do not allow smoking, open flame, or sparks near battery during charging or servicing.
- Do not contact tools or other metal objects across the battery terminals.
- Always wear hand, eye, and face protection when servicing batteries. Ensure that battery acid does not come in contact with skin or clothing.

CAUTION

BATTERY FLUID IS HIGHLY CORROSIVE. AVOID CONTACT WITH SKIN AND CLOTHING AT ALL TIMES. IMMEDIATELY RINSE ANY CONTACTED AREA WITH CLEAN WATER AND SEEK MEDICAL ATTENTION.

- Charge batteries only in a well ventilated area.
- Avoid overfilling the battery fluid level. Add distilled water to batteries only after the batteries are fully charged.

SECTION 1 - SAFETY PRECAUTIONS



NOTES:

SECTION 2. USER RESPONSIBILITIES, MACHINE PREPARATION, AND INSPECTION

2.1 PERSONNEL TRAINING

The aerial platform is a personnel handling device; so it is necessary that it be operated and maintained only by trained personnel.

Persons under the influence of drugs or alcohol or who are subject to seizures, dizziness or loss of physical control must not operate this machine.

Operator Training

Operator training must cover:

1. Use and limitations of the controls in the platform and at the ground, emergency controls and safety systems.
2. Control labels, instructions, and warnings on the machine.
3. Rules of the employer and government regulations.
4. Use of approved fall protection device.
5. Enough knowledge of the mechanical operation of the machine to recognize a malfunction or potential malfunction.

6. The safest means to operate the machine where overhead obstructions, other moving equipment, and obstacles, depressions, holes, drop-offs.
7. Means to avoid the hazards of unprotected electrical conductors.
8. Specific job requirements or machine application.

Training Supervision

Training must be done under the supervision of a qualified person in an open area free of obstructions until the trainee has developed the ability to safely control and operate the machine.

Operator Responsibility

The operator must be instructed that he/she has the responsibility and authority to shut down the machine in case of a malfunction or other unsafe condition of either the machine or the job site.

2.2 PREPARATION, INSPECTION, AND MAINTENANCE

The following table covers the periodic machine inspections and maintenance required by JLG Industries, Inc. Consult local regulations for further requirements for aerial work platforms. The frequency of inspections and maintenance must be increased as necessary when the machine is used in a harsh or hostile environment, if the machine is used with increased frequency, or if the machine is used in a severe manner.

NOTICE

JLG INDUSTRIES, INC. RECOGNIZES A FACTORY-QUALIFIED SERVICE TECHNICIAN AS A PERSON WHO HAS SUCCESSFULLY COMPLETED THE JLG SERVICE TRAINING SCHOOL FOR THE SPECIFIC JLG PRODUCT MODEL.

SECTION 2 - USER RESPONSIBILITIES, MACHINE PREPARATION, AND INSPECTION

Table 2-1. Inspection and Maintenance Table

Type	Frequency	Primary Responsibility	Service Qualification	Reference
Pre-Start Inspection	Before using each day; or whenever there's an Operator change.	User or Operator	User or Operator	Operator and Safety Manual
Pre-Delivery Inspection (See Note)	Before each sale, lease, or rental delivery.	Owner, Dealer, or User	Qualified JLG Mechanic	Service and Maintenance Manual and applicable JLG inspection form
Frequent Inspection (See Note)	In service for 3 months or 150 hours, whichever comes first; or Out of service for a period of more than 3 months; or Purchased used.	Owner, Dealer, or User	Qualified JLG Mechanic	Service and Maintenance Manual and applicable JLG inspection form
Annual Machine Inspection (See Note)	Annually, no later than 13 months from the date of prior inspection.	Owner, Dealer, or User	Factory-Qualified Service Technician (Recommended)	Service and Maintenance Manual and applicable JLG inspection form
Preventative Maintenance	At intervals as specified in the Service and Maintenance Manual.	Owner, Dealer, or User	Qualified JLG Mechanic	Service and Maintenance Manual

NOTE: Inspection forms are available from JLG. Use the Service and Maintenance Manual to perform inspections.

SECTION 2 - USER RESPONSIBILITIES, MACHINE PREPARATION, AND INSPECTION

Pre-Start Inspection

The Pre-Start Inspection should include each of the following:

1. **Cleanliness** – Check all surfaces for leakage (oil, fuel, or battery fluid) or foreign objects. Report any leakage to the proper maintenance personnel.
2. **Structure** - Inspect the machine structure for dents, damage, weld or parent metal cracks or other discrepancies.

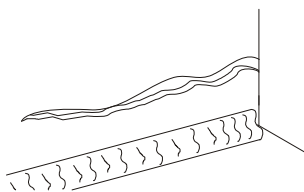

Parent Metal Crack

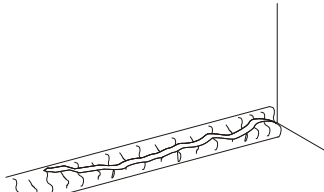

Weld Crack

3. **Decals and Placards** – Check all for cleanliness and legibility. Make sure none of the decals and placards are missing. Make sure all illegible decals and placards are cleaned or replaced.
4. **Operators and Safety Manuals** – Make sure a copy of the Operator and Safety Manual, EMI Safety Manual (Domestic only), and ANSI Manual of Responsibilities (Domestic only) is enclosed in the weather resistant storage container.

5. **“Walk-Around” Inspection** – Refer to Figure 2-2. and Figure 2-3.
6. **Battery** – Charge as required.
7. **Fuel** (Combustion Engine Powered Machines) – Add the proper fuel as necessary.
8. **Engine Oil Supply** - Ensure the engine oil level is at the Full mark on the dipstick and the filler cap is secure.
9. **Hydraulic Oil** – Check the hydraulic oil level. Ensure hydraulic oil is added as required.
10. **Accessories/Attachments** - Reference the Operator and Safety Manual of each attachment or accessory installed upon the machine for specific inspection, operation, and maintenance instructions.
11. **Function Check** – Once the “Walk-Around” Inspection is complete, perform a functional check of all systems in an area free of overhead and ground level obstructions. Refer to Section 4 for more specific operating instructions.
12. **Boom Control System Check** - Perform a check of the boom control system as specified in this section.

WARNING

IF THE MACHINE DOES NOT OPERATE PROPERLY, TURN OFF THE MACHINE IMMEDIATELY! REPORT THE PROBLEM TO THE PROPER MAINTENANCE PERSONNEL. DO NOT OPERATE THE MACHINE UNTIL IT IS DECLARED SAFE FOR OPERATION.

Function Check

Perform the Function Check as follows:

1. From the ground control panel with no load in the platform:
 - a. Check that all guards protecting the switches or locks are in place;
 - b. Operate all functions and check all limiting and cut-out switches;
 - c. Check auxiliary power (or manual descent);
 - d. Ensure that all machine functions are disabled when the Emergency Stop Button is activated.
2. Check the Boom Control System. Refer to Boom Control System Check Procedure below.
3. From the platform control console:
 - a. Ensure that the control console is firmly secured in the proper location;
 - b. Check that all guards protecting the switches or locks are in place;
 - c. Operate all functions and check all limiting and cut-out switches;
 - d. Ensure that all machine functions are disabled when the Emergency Stop Button is pushed in.
4. With the platform in the (stowed) position:
 - a. Drive the machine on a grade, not to exceed the rated gradeability, and stop to ensure the brakes hold;
 - b. Check the tilt sensor alarm to ensure proper operation.
 - c. Check that the boom telescope (beyond transport mode) and lift up (more than 15° above horizontal) functions are disabled with the axles retracted.
5. Swing the boom over either of the rear tires and ensure that the Drive Orientation indicator illuminates and that the Drive Orientation Override switch must be used for the drive function to operate.

Boom Control System Check Procedure

Perform the following check with no load (personnel or material) in the platform from the ground control station.

1. Extend all axles fully.
2. With the boom fully retracted, raise the boom off the boom rest to horizontal.
3. Position the jib horizontal, jib straight, and platform level.
4. Extend the boom until it stops.
5. Boom must stop on colored stripe matching the capacity indicator. If the boom does not stop on the correct stripe, the system must be repaired by JLG authorized Service Personnel before the machine can be used.
6. Push and hold the gray Boom Control System Test Button on the ground control panel. The lighting of the green Boom Control System Calibrated indicator indicates the system is functioning properly. No indicator light or the lighting of the red Boom Control System Warning indicator indicates the system must be repaired by JLG authorized Service Personnel before the machine can be used.

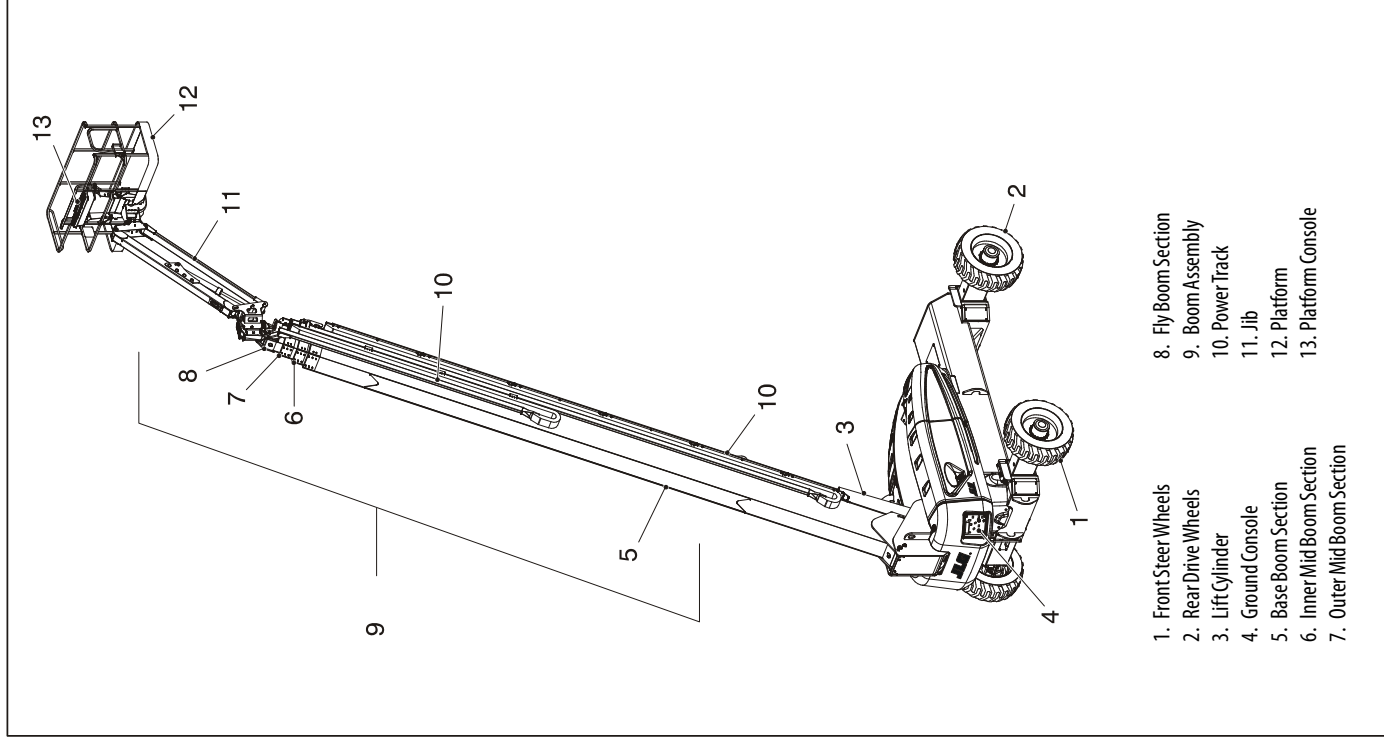

Figure 2-1. Basic Nomenclature

SECTION 2 - USER RESPONSIBILITIES, MACHINE PREPARATION, AND INSPECTION

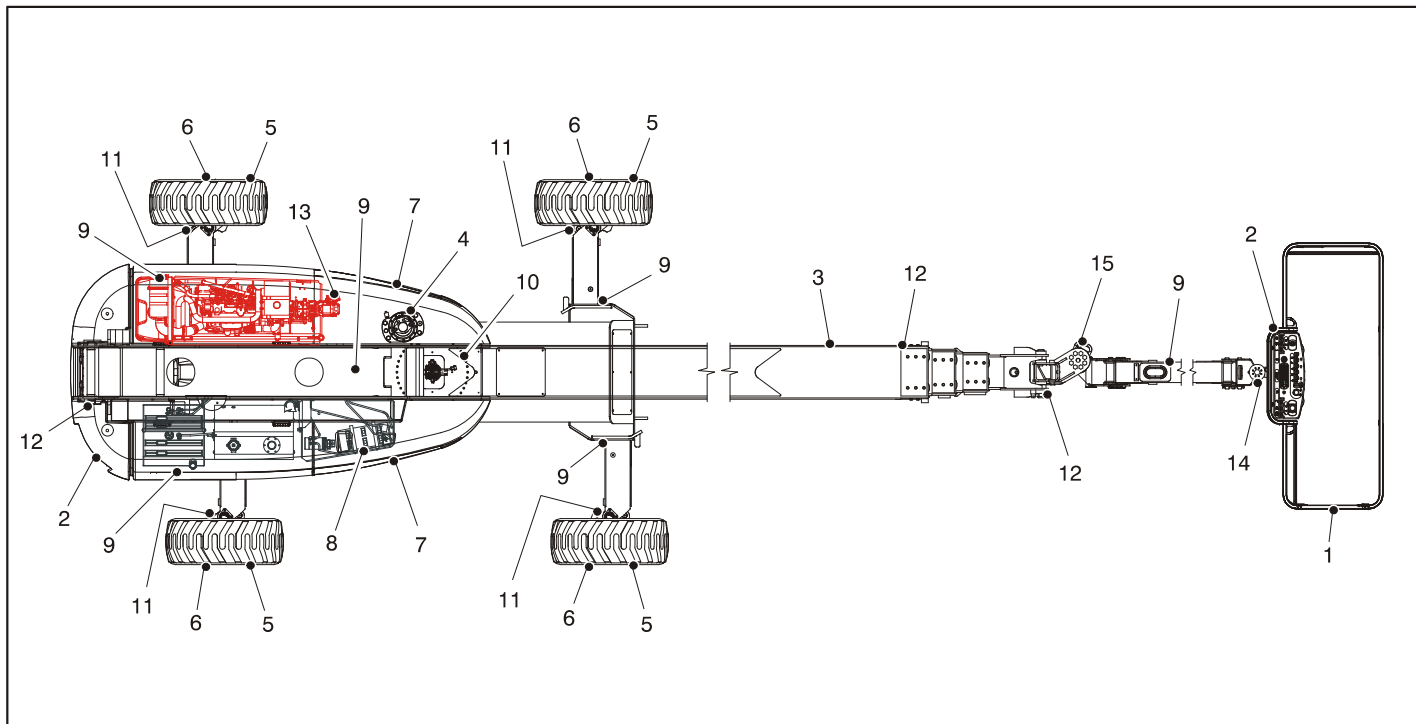

Figure 2-2. Daily Walk-Around Inspection - Sheet 1 of 3

General

Begin the "Walk-Around Inspection" at Item 1, as noted on the diagram. Continue to the right (counterclockwise viewed from top) checking each item in sequence for the conditions listed in the following checklist.

WARNING

TO AVOID POSSIBLE INJURY, BE SURE MACHINE POWER IS OFF.

DO NOT OPERATE MACHINE UNTIL ALL MALFUNCTIONS HAVE BEEN CORRECTED.

INSPECTION NOTE: *On all components, make sure there are no loose or missing parts, that they are securely fastened, and no visible damage, leaks or excessive wear exists in addition to any other criteria mentioned.*

- 1. Platform Assembly and Gate** - Footswitch works properly, not modified, disabled or blocked. Latch, stop, and hinges in working condition.
- 2. Platform & Ground Control Consoles** - Switches and levers return to neutral, decals/placards secure and legible, control markings legible.
- 3. Boom Sections/Uprights/Turntable** - See Inspection Note.
- 4. Swing Drive** - No evidence of damage.
- 5. Wheel/Tire Assemblies** - Properly secured, no missing lug nuts. Inspect for worn tread, cuts, tears or other discrepancies. Inspect wheels for damage and corrosion.
- 6. Drive Motor, Brake, and Hub** - No evidence of leakage.
- 7. Hood Assemblies** - See Inspection Note.
- 8. Auxiliary Hydraulic Pump** - See Inspection Note.
- 9. All Hydraulic Cylinders** - No visible damage; pivot pins and hydraulic hoses undamaged, not leaking.
- 10. Turntable Bearing** - Evidence of proper lubrication. No evidence of loose bolts or looseness between bearing and machine.
- 11. Steering Spindles and Sensors** - See Inspection Note.

Figure 2-3. Daily Walk-Around Inspection - Sheet 2 of 3

SECTION 2 - USER RESPONSIBILITIES, MACHINE PREPARATION, AND INSPECTION

- 12. Horizontal and Capacity Limit Switches** - Switches operate properly.
- 13. Main Hydraulic Pump** - See Inspection Note.
- 14. Platform Rotator** - See Inspection Note.
- 15. Jib Rotator** - See Description.

Figure 2-4. Daily Walk-Around Inspection - Sheet 3 of 3

2.3 OSCILLATING AXLE LOCKOUT TEST (IF EQUIPPED)

The front axles will oscillate when the boom is in the transport position (i.e. when the boom is less than 15° above horizontal and not extended beyond 12" [30.4 cm] on the 1350SJP or 24" [60.9 cm] on the 1200SJP) and drive is selected.

NOTICE

LOCKOUT SYSTEM TEST MUST BE PERFORMED QUARTERLY, ANY TIME A SYSTEM COMPONENT IS REPLACED, OR WHEN IMPROPER SYSTEM OPERATION IS SUSPECTED.

NOTE: *Ensure the axles are extended and the boom is fully retracted, lowered, and centered between the rear wheels prior to beginning lockout cylinder test.*

1. Place a 6 inches (15.2 cm) high block with ascension ramp in front of left front wheel.
2. From platform control station, start engine.
3. Place the Drive control lever to the forward position and carefully drive machine up ascension ramp until left front wheel is on top of block.
4. Carefully extend the boom just enough to get it out of the transport position.
5. With boom in this position, place Drive control lever to Reverse and carefully drive machine off of block and ramp.

6. Have an assistant check to see that left front or right rear wheel remains elevated in position off of the ground.
7. Carefully return the boom to the transport position. When boom reaches the transport position, carefully activate Drive to release cylinders. The lockout cylinders should release and allow the wheel to rest on ground.
8. Repeat the procedure for the right oscillation cylinder checking to see that the right front or left rear wheel remains elevated in position off of the ground.
9. If lockout cylinders do not function properly, have qualified personnel correct the malfunction prior to any further operation.

SECTION 2 - USER RESPONSIBILITIES, MACHINE PREPARATION, AND INSPECTION

 **NOTES:**

<hr/>	<hr/>
<hr/>	<hr/>
<hr/>	<hr/>
<hr/>	<hr/>
<hr/>	<hr/>
<hr/>	<hr/>
<hr/>	<hr/>
<hr/>	<hr/>
<hr/>	<hr/>
<hr/>	<hr/>
<hr/>	<hr/>
<hr/>	<hr/>
<hr/>	<hr/>
<hr/>	<hr/>
<hr/>	<hr/>
<hr/>	<hr/>
<hr/>	<hr/>
<hr/>	<hr/>
<hr/>	<hr/>
<hr/>	<hr/>

SECTION 3. MACHINE CONTROLS AND INDICATORS

3.1 GENERAL

NOTICE

THE MANUFACTURER HAS NO DIRECT CONTROL OVER MACHINE APPLICATION AND OPERATION. THE USER AND OPERATOR ARE RESPONSIBLE FOR CONFORMING WITH GOOD SAFETY PRACTICES.

This section provides the necessary information needed to understand control functions.

3.2 CONTROLS AND INDICATORS

NOTE: This machines is equipped with control panels that use symbols to indicate control functions. Refer to decal located on the control box guard in front of the control box or by the ground controls for these symbols and the corresponding functions.

WARNING

TO AVOID SERIOUS INJURY, DO NOT OPERATE MACHINE IF ANY CONTROL LEVERS OR TOGGLE SWITCHES CONTROLLING PLATFORM MOVEMENT DO NOT RETURN TO THE OFF POSITION WHEN RELEASED.

Ground Control Station

NOTE: If equipped, the Function Enable switch must be held down in order to operate Telescope, Swing, Main Lift, Jib Lift, Platform Level Override, and Platform Rotate functions.



(See Figure 3-1., Ground Control Station)

1. Indicator Panel

The LED Indicator Panel contains indicator lights that signal problem conditions or functions operating during machine operation.

2. Boom Control System Test Button

The push button is used to test the boom control system and confirm that it is working properly.

3. Telescope Control

Provides extension and retraction of the boom when positioned to IN or OUT.

SECTION 3 - MACHINE CONTROLS AND INDICATORS

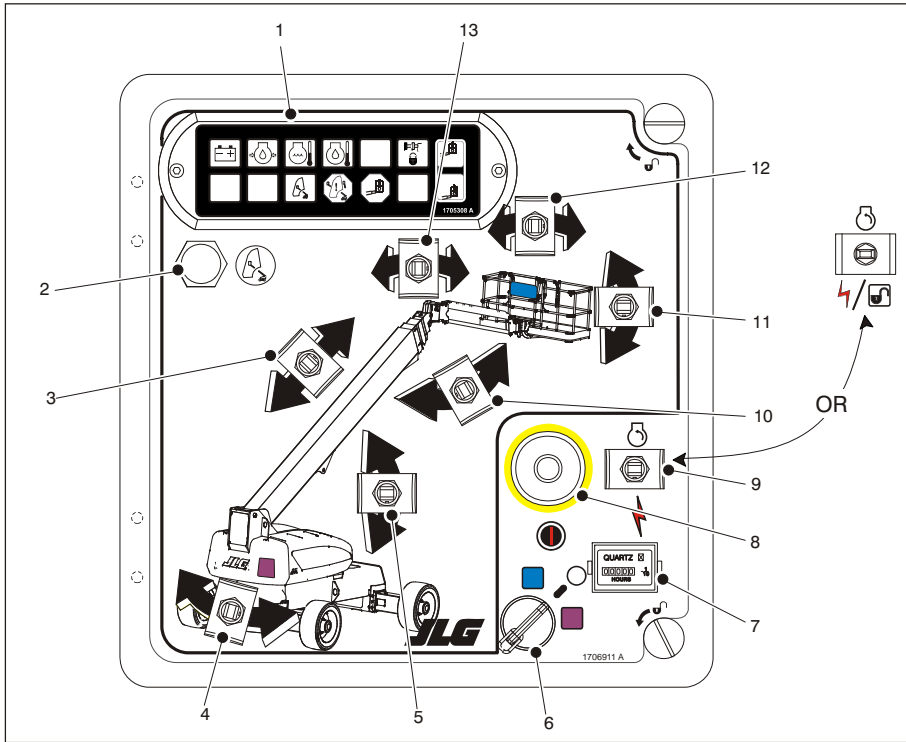

1. Indicator Panel
2. Boom Control System Test Button
3. Telescope
4. Swing
5. Lift
6. Platform/Ground Select Switch
7. Hourmeter
8. Power/Emergency Stop
9. Engine Start/Auxiliary Power
or
Engine Start/Auxiliary Power/Function Enable
10. Articulating Jib
11. Platform Leveling Override
12. Platform Rotate
13. Jib Swing

Figure 3-1. Ground Control Station

4. Swing Control

Provides 360 degrees continuous turntable rotation.

5. Lift Control

Provides raising and lowering of the main boom.

NOTE: With PLATFORM/GROUND SELECT switch in the center position, power is shut off to controls at both operating stations.

6. Platform/Ground Select Switch

A three position, key operated switch supplies power to the platform control console when positioned to PLATFORM. With the switch key held in the GROUND position, power is shut off to platform and only ground controls are operable.

7. Hourmeter

Registers the amount of time the machine has been in use, with engine running. By connecting into the oil pressure circuit of the engine, only engine run hours are recorded. The hourmeter registers up to 9,999.9 hours and cannot be reset.

NOTE: When Power/Emergency Stop switch is in the "ON" position and engine is not running, an alarm will sound, indicating Ignition is "ON".



WHEN THE MACHINE IS SHUT DOWN THE MASTER/EMERGENCY STOP SWITCH MUST BE POSITIONED TO THE "OFF" POSITION TO PREVENT DRAINING THE BATTERY.

8. Power/Emergency Stop Switch

A two-position red mushroom shaped switch furnishes power to PLATFORM/GROUND SELECT switch when pulled out (on). When pushed in (off), power is shut off to the PLATFORM/GROUND SELECT switch.

SECTION 3 - MACHINE CONTROLS AND INDICATORS

NOTE: Auxiliary power only works if there is no engine oil pressure, and is disabled if engine is running.

Functions will operate at a slower than normal rate because of the lesser flow of hydraulic fluid delivered.

CAUTION

WHEN USING AUXILIARY POWER, DO NOT OPERATE MORE THAN ONE FUNCTION AT A TIME. (SIMULTANEOUS OPERATION CAN OVERLOAD THE AUXILIARY PUMP.)

9. Engine Start/Auxiliary Power Switch
or

Engine Start/ Auxiliary Power Switch /Function Enable

To start the engine, the switch must be held "UP" until the engine starts.



To use auxiliary power, the switch must be held "DOWN" for duration of auxiliary pump use. Aux power can only be used if the engine is not running.



If equipped, the enable switch must be held "DOWN" to enable all boom controls when the engine is running.



10. Articulating Jib

This switch provides raising and lowering of the jib.

WARNING

ONLY USE THE PLATFORM LEVELING OVERRIDE FUNCTION FOR SLIGHT LEVELING OF THE PLATFORM. INCORRECT USE COULD CAUSE THE LOAD/OCCUPANTS TO SHIFT OR FALL. FAILURE TO DO SO COULD RESULT IN DEATH OR SERIOUS INJURY.

11. Platform Leveling Override

A three position switch allows the operator to adjust the automatic self leveling system. This switch is used to adjust platform level in situations such as ascending/descending a grade.

12. Platform Rotate

A three position switch permits rotation of the platform.

13. Jib Rotate

A three position switch permits rotation of the jib and platform.

Ground Control Indicator Panel

(See Figure 3-2., Ground Control Indicator Panel)

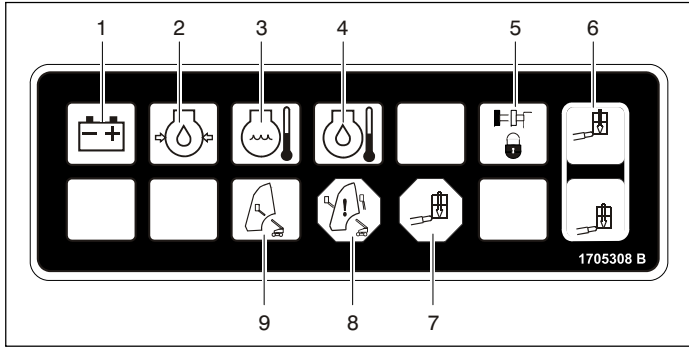

- | | |
|------------------------------|-----------------------------------|
| 1. Battery Charging | 6. Platform Capacity |
| 2. Low Engine Oil Pressure | 7. Platform Overload |
| 3. High Engine Coolant Temp. | 8. Boom Control System Warning |
| 4. High Engine Oil Temp. | 9. Boom Control System Calibrated |
| 5. Axles Set | |

Figure 3-2. Ground Control Indicator Panel

1. Battery Charging Indicator

Indicates a problem in the battery or charging circuit, and service is required.

2. Low Engine Oil Pressure Indicator

Indicates that engine oil pressure is below normal and service is required.

3. High Engine Temperature Indicator

Indicates that engine coolant temperature is abnormally high and service is required.

4. Engine Oil Temperature Indicator

Indicates the temperature of the engine oil, which also serves as engine coolant, is abnormally high and service is required.

5. Axles Set Indicator

Indicates that the axles are fully extended. The indicator will flash as the axles are extending or retracting and be on solid when fully extended. The light will go out when the axles are fully retracted.

6. Platform Capacity Indicator

Indicates which capacity range is selected. This capacity can only be selected at the platform control console.

SECTION 3 - MACHINE CONTROLS AND INDICATORS

7. Platform Overload Indicator (If Equipped)

Indicates the platform has been overloaded.

8. Boom Control System Warning Indicator

Indicates the platform is outside the operating area and operation of certain boom functions may be disabled (i.e. lift, telescope). Attempts to use the disabled functions cause the indicator to flash and an alarm to sound. Immediately return the platform to the ground. If the indicator remains lit, a boom control system fault or failure has been detected. If a failure is discovered, the system must be repaired by JLG authorized service personnel before the machine can be used.

9. Boom Control System Calibrated Indicator

When the Boom Control System Test Button is pushed, illuminates to indicate that the Boom Control System is calibrated properly.

Platform Station

(See Figure 3-3., Platform Control Console - Prior to S/N 79596, Figure 3-4., Platform Control Console - S/N 79596 to 93078, and Figure 3-5., Platform Control Console - w/Boom Control Select)

WARNING

TO AVOID SERIOUS INJURY, DO NOT OPERATE MACHINE IF ANY CONTROL LEVERS OR TOGGLE SWITCHES CONTROLLING PLATFORM MOVEMENT DO NOT RETURN TO THE OFF OR NEUTRAL POSITION WHEN RELEASED.

1. Power/Emergency Stop

A two-position red mushroom shaped switch furnishes power to PLATFORM Controls when pulled out (on). When pushed in (off), power is shut off to the platform functions.

Within about 2 seconds of pulling the switch out, the machine will perform a diagnostic check of the various electrical circuits, and if everything is OK, the platform alarm will beep once. During this time the lights on the indicator panel will also blink once as a bulb check.

2. Start/Auxiliary Power

When pushed forward, the switch energizes the starter motor to start the engine.

When pushed back, it energizes the electrically operated hydraulic pump, when actuated. (Switch must be held ON for duration of auxiliary pump use.)

The auxiliary pump functions to provide sufficient oil flow to operate the basic machine functions should the main pump or engine fail. The auxiliary pump will operate platform rotate, jib lift, jib swing, platform level override, main boom lift, main telescope and swing.

3. Capacity Select

This switch allows the operator to select between an operating envelope with a 500 lb. (227 kg for ANSI markets and 230 kg for CE and Australia markets) capacity restriction or a 1000 lb. (454 kg for ANSI markets and 450 kg for CE and Australia markets) capacity restriction.

4. Drive Orientation Override

When the boom is swung over the rear tires or further in either direction, the Drive Orientation indicator will illuminate when the drive function is selected. Push and release the switch, and within 3 seconds move the Drive/Steer control to activate drive or steer. Before driving, locate the black/white orientation arrows on both the chassis and the platform controls. Move the drive controls in a direction matching the directional arrows.

NOTE: *To operate the Drive Joystick, pull up on the locking ring below the handle.*

NOTE: *The DRIVE control levers are spring-loaded and will automatically return to neutral (OFF) position when released.*

5. Drive/Steer

The DRIVE joystick provides for driving either forward or backward. The controller is 'ramped' to allow variable drive speed.

Steering is controlled by a thumb operated switch on top of the joystick.

SECTION 3 - MACHINE CONTROLS AND INDICATORS

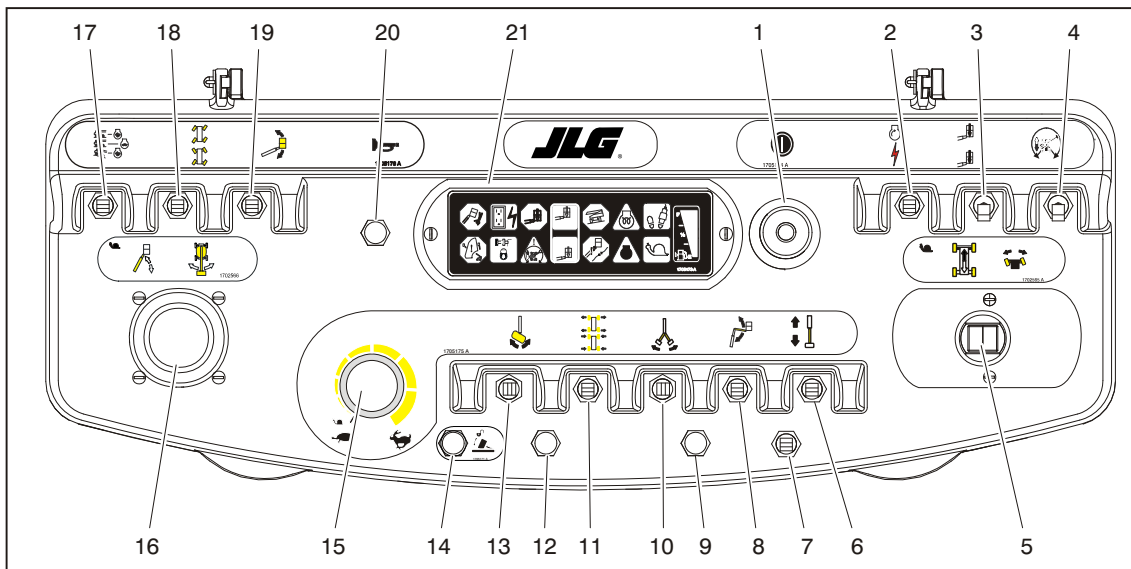

- | | | | | |
|-------------------------------|------------------------|--------------------------|---------------------------------|-----------------------------|
| 1. Power/Emergency Stop | 6. Telescope | 10. Jib Swing | 14. Jib Stow Override | 18. Steer Select |
| 2. Engine Start / Aux Power | 7. Lights | 11. Axle Extend/Retract | 15. Function Speed Control | 19. Platform Level Override |
| 3. Capacity Select | 8. Jib Lift | 12. Soft Touch Indicator | 16. Main Lift / Swing | 20. Horn |
| 4. Drive Orientation Override | 9. Soft Touch Override | 13. Platform Rotate | 17. Drive Speed / Torque Select | 21. Indicator Panel |
| 5. Drive/Steer | | | | |

Figure 3-3. Platform Control Console - Prior to S/N 79596

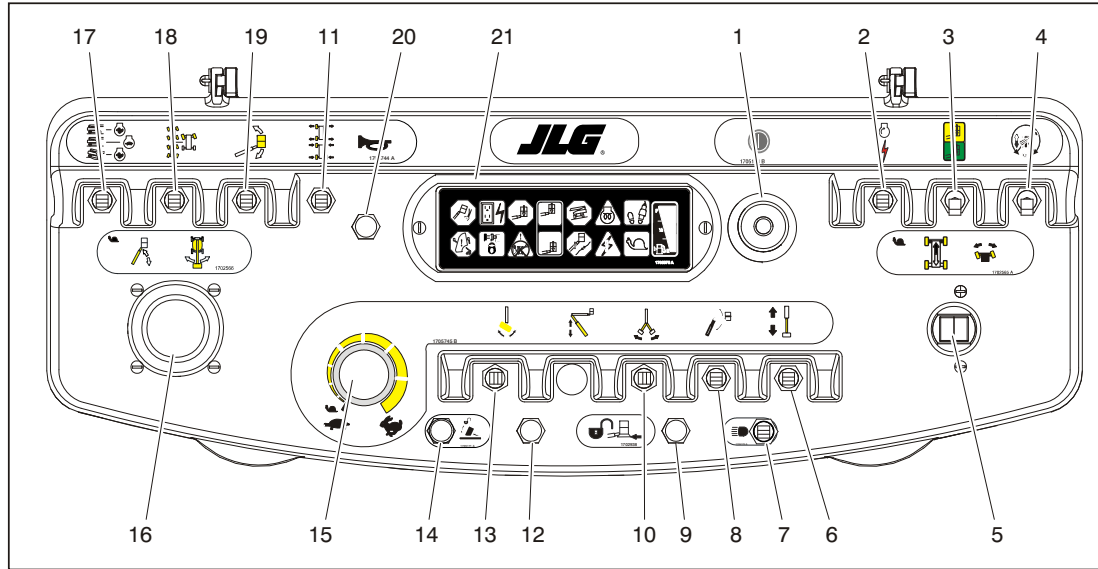

- | | | | | |
|-------------------------------|------------------------|--------------------------|---------------------------------|-----------------------------|
| 1. Power/Emergency Stop | 6. Telescope | 10. Jib Swing | 14. Jib Stow Override | 18. Steer Select |
| 2. Engine Start / Aux Power | 7. Lights | 11. Axle Extend/Retract | 15. Function Speed Control | 19. Platform Level Override |
| 3. Capacity Select | 8. Jib Lift | 12. Soft Touch Indicator | 16. Main Lift / Swing | 20. Horn |
| 4. Drive Orientation Override | 9. Soft Touch Override | 13. Platform Rotate | 17. Drive Speed / Torque Select | 21. Indicator Panel |
| 5. Drive/Steer | | | | |

Figure 3-4. Platform Control Console - S/N 79596 to 93078

SECTION 3 - MACHINE CONTROLS AND INDICATORS

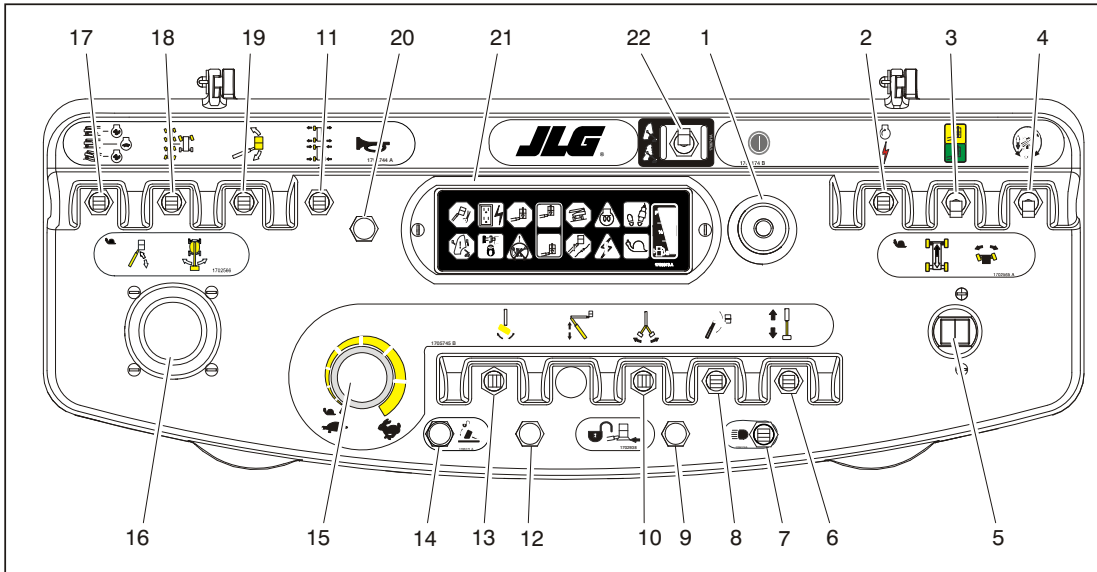

- | | | | | |
|-------------------------------|------------------------|--------------------------|---------------------------------|-----------------------------|
| 1. Power/Emergency Stop | 6. Telescope | 11. Axle Extend/Retract | 15. Function Speed Control | 19. Platform Level Override |
| 2. Engine Start / Aux Power | 7. Lights | 12. Soft Touch Indicator | 16. Main Lift / Swing | 20. Horn |
| 3. Capacity Select | 8. Jib Lift | 13. Platform Rotate | 17. Drive Speed / Torque Select | 21. Indicator Panel |
| 4. Drive Orientation Override | 9. Soft Touch Override | 14. Jib Stow Override | 18. Steer Select | 22. Boom Control Select |
| 5. Drive/Steer | 10. Jib Swing | | | |

Figure 3-5. Platform Control Console - w/Boom Control Select

SECTION 3 - MACHINE CONTROLS AND INDICATORS

6. Main Telescope

This control allows extension and retraction of the main boom.

7. Lights (If Equipped)

This switch operates accessory light packages if the machine is so equipped.

8. Jib Lift

Push forward to lift up, pull back to lift down. Variable lift speed is using the Function Speed Control.

9. Soft Touch Override Switch (If equipped)

This switch enables the functions that were cut out by the Soft Touch system to operate again at creep speed, allowing the operator to move the platform away from the obstacle that caused the shutdown situation.

NOTE: *The Jib Swing function is not operable when the Capacity Select control is in the 1000 lb. (454 kg for ANSI markets and 450 kg for CE and Australia markets) position.*

10. Jib Swing

This switch allows the operator to rotate the jib to the left or right.

11. Axle Extend/Retract

This switch allows the operator to extend or retract the axles. The axles can only be extended or retracted while the machine is being driven forward or reverse.

12. Soft Touch Indicator (If Equipped)

Indicates the Soft Touch bumper is against an object. All controls are cut out until the override button is pushed, at which time controls are active in the Creep Mode.

13. Platform Rotate

This switch allows the operator to rotate the basket to the left or right.

SECTION 3 - MACHINE CONTROLS AND INDICATORS

14. Jib Stow Override

This switch allows the operator to rotate the jib to the right past the electronic stop to stow the jib under the boom for transport.

15. Function Speed Control

Controls the speed of Boom and Swing Functions. Rotate CCW for slower speed and CW for faster speed. To adjust to creep, turn knob fully CCW until it clicks.

NOTE: *To operate the Main Lift/Swing Joystick, pull up on the locking ring below the handle.*

NOTE: *The MAIN LIFT/SWING control lever is spring-loaded and will automatically return to neutral (OFF) position when released.*

16. Main Lift/Swing Controller

An infinitely proportional dual axis joystick is provided for main lift and swing. Push forward to lift up, pull backward to lift down. Move right to swing right, move left to swing left.

NOTE: *When boom is positioned above transport position or telescoped out and any of the following switches, DRIVE SPEED/TORQUE SELECT or FUNCTION SPEED, are positioned to HIGH, high function speeds are automatically cut out and the machine continues to operate at a lower speed.*



DO NOT OPERATE MACHINE IF DRIVE SPEED /TORQUE SELECT OR FUNCTION SPEED SWITCHES OPERATE WHEN BOOM IS MORE THAN 15° ABOVE HORIZONTAL.

17. Drive Speed/Torque Select

The forward position gives maximum drive speed by shifting the drive motors to minimum displacement and giving high engine when drive controller is moved. The back position gives maximum torque for rough terrain and climbing grades by shifting the wheel motors to maximum displacement and giving high engine speed when drive controller is moved. The center position allows the machine to be driven as quietly as possible by leaving the engine at mid speed and the drive motors in maximum displacement.

18. Steer Select

When equipped with four wheel steering, the action of the steering system is operator selectable. The center switch position gives conventional front wheel steering with the rear wheels unaffected. This is for normal driving at maximum speeds. The forward position is for "crab" steering. When in this mode both front and rear axles steer in the same direction, which allows the chassis to move sideways as it goes forward. This can be used for positioning the machine in aisle ways or against buildings. The back switch position is for "coordinated" steering. In this mode the front and rear axles steer in the opposite directions to produce the tightest turning circle for maneuvering in confined areas.

WARNING

ONLY USE THE PLATFORM LEVELING OVERRIDE FUNCTION FOR SLIGHT LEVELING OF THE PLATFORM. INCORRECT USE COULD CAUSE THE LOAD/OCCUPANTS TO SHIFT OR FALL. FAILURE TO DO SO COULD RESULT IN DEATH OR SERIOUS INJURY.

19. Platform Leveling Override

A three position switch allows the operator to adjust the automatic self leveling system. This switch is used to adjust platform level in situations such as ascending/descending a grade.

20. Horn

If pressed, this switch supplies power to the horn.

SECTION 3 - MACHINE CONTROLS AND INDICATORS

21. Indicator Panel

The LED Indicator Panel contains indicator lights that signal problem conditions or functions operating during machine operation.

22. Boom Control Select

Automatic Mode:

When the Boom Control is positioned to Automatic, lift and telescope movements are coordinated by the JLG control system and the automatic platform leveling feature is active during lift, telescope, swing, and drive movements.



- NOTE:**
- While operating lift up, the boom may also telescope out.
 - While operating lift down, the boom may also telescope in.
 - While operating swing or drive, the boom may lift up or lift down.
 - While operating telescope in, the boom may lift down when at high boom angles and the creep light is flashing.

Manual Mode:

When the boom control is positioned to Manual, lift and telescope movements are controlled separately by the operator and the automatic platform leveling feature is active only during lift functions.



NOTE: When positioned to Manual, boom functions will be stopped when the envelope limits are reached. When this occurs, operate a different function or select the automatic position.

NOTE: Depending upon the angle of the chassis and the angle of the boom, swing left or swing right may be disallowed while in the Manual mode. The BCS light will illuminate and further attempts to swing in the disallowed direction will cause the BCS to flash. When this occurs the only choices are to swing in the opposite direction or switch to automatic mode.

Platform Control Indicator Panel

(See Figure 3-6. or Figure 3-7.)

NOTE: *The platform control indicator panel uses different shaped symbols to alert the operator to different types of operational situations that could arise. The meaning of those symbols are explained below.*



Indicates a potentially hazardous situation, which if not corrected, could result in serious injury or death. This indicator will be red.



Indicates an abnormal operating condition, which if not corrected, may result in machine interruption or damage. This indicator will be yellow.



Indicates important information regarding the operating condition, i.e. procedures essential for safe operation. This indicator will be green with the exception of the capacity indicator which will be green or yellow depending upon platform position.

1. Level System Fault Indicator

Indicates a fault in the electronic leveling system. The fault indicator will flash and an alarm sound. All functions will

default to creep if the boom is extended past transport mode (24 inches [61 cm] 1200; 12 inches [30.5 cm] 1350) or elevated more than 15° above horizontal.

WARNING

IF THE LEVEL SYSTEM FAULT INDICATOR IS ILLUMINATED, SHUT DOWN THE MACHINE, RECYCLE THE EMERGENCY STOP, AND RESTART THE MACHINE. IF THE FAULT PERSISTS, RETURN THE PLATFORM TO THE STOWED POSITION, USING MANUAL LEVELING AS REQUIRED, AND HAVE LEVELING SYSTEM REPAIRED.

2. AC Generator

Indicates the generator is in operation.

3. Platform Overload Indicator (If Equipped)

Indicates the platform has been overloaded.

4. Platform Capacity Indicator

Indicates the maximum platform capacity selected for the platform.

One of the capacity lights should be on at all times. Both lights will flash and an alarm will sound if the platform is out of the operating envelope for the selected capacity.

SECTION 3 - MACHINE CONTROLS AND INDICATORS

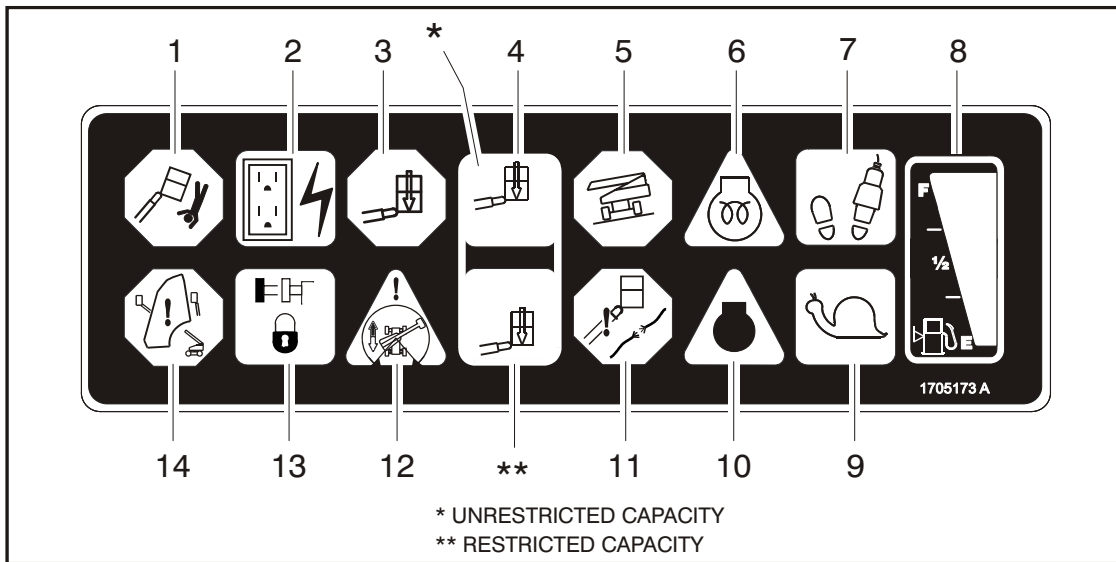

- | | | |
|-----------------------|---------------------|---------------------------------|
| 1. Level System | 6. Glow Plug | 11. Cable Service |
| 2. AC Generator | 7. Enable | 12. Drive Orientation |
| 3. Platform Overload | 8. Fuel Level | 13. Axles Set |
| 4. Platform Capacity | 9. Creep Speed | 14. Boom Control System Warning |
| 5. Tilt Alarm Warning | 10. System Distress | |

Figure 3-6. Platform Control Indicator Panel - Prior to S/N 79596

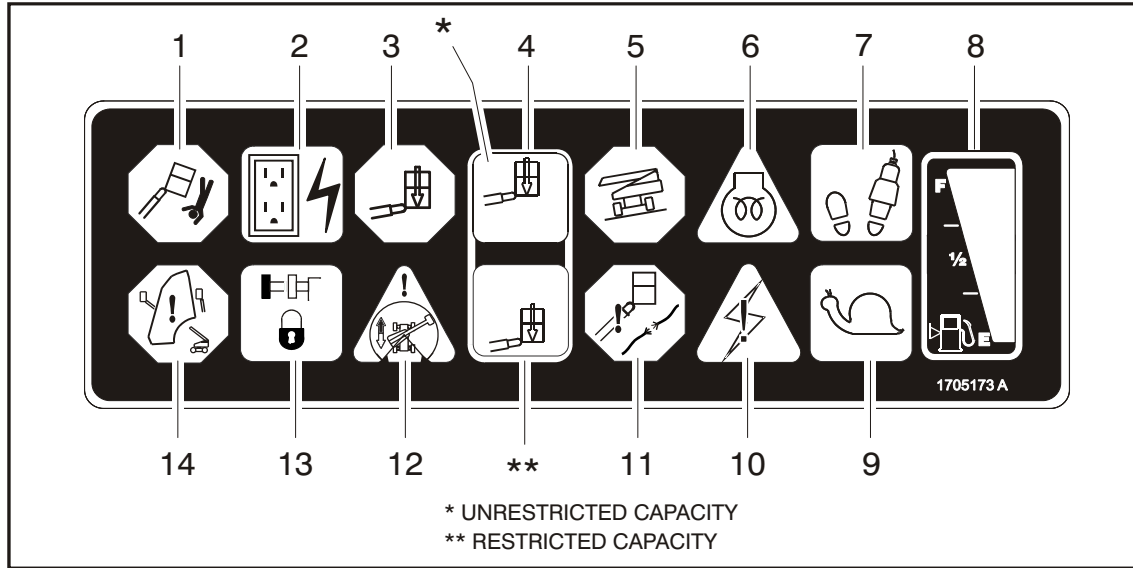

- | | | |
|-----------------------|---------------------|---------------------------------|
| 1. Level System | 6. Glow Plug | 11. Cable Service |
| 2. AC Generator | 7. Enable | 12. Drive Orientation |
| 3. Platform Overload | 8. Fuel Level | 13. Axles Set |
| 4. Platform Capacity | 9. Creep Speed | 14. Boom Control System Warning |
| 5. Tilt Alarm Warning | 10. System Distress | |

Figure 3-7. Platform Control Indicator Panel - S/N 79596 to Present

SECTION 3 - MACHINE CONTROLS AND INDICATORS

5. Tilt Alarm Warning Light and Alarm

Indicates that the chassis is on a slope. An alarm will also sound when the chassis is on a slope and the boom is above transport position. If lit when the boom is raised or extended, retract and lower to below horizontal then reposition machine so that it is level before continuous operation. If the boom is above transport position or telescoped, out and the machine is on a slope, the tilt alarm warning light will illuminate and an alarm will sound and CREEP is automatically activated.

WARNING

IF ILLUMINATED WHEN BOOM IS RAISED OR EXTENDED, RETRACT AND LOWER TO BELOW HORIZONTAL THEN REPOSITION MACHINE SO THAT IT IS LEVEL BEFORE EXTENDING BOOM OR RAISING BOOM more than 15 degrees ABOVE HORIZONTAL.

6. Glow Plug Indicator

Indicates the glow plugs are operating. After turning on ignition, wait until light goes out before cranking engine.

7. Footswitch/Enable Indicator

To operate any function, the footswitch must be depressed and the function selected within seven seconds. The enable indicator shows that the controls are enabled. If a function is not selected within seven seconds, or if a seven second lapse between ending one function and beginning the next function, the enable light will go out and the footswitch must be released and depressed again to enable the controls.

Releasing the footswitch removes power from all controls and applies the drive brakes.

WARNING

TO AVOID SERIOUS INJURY, DO NOT REMOVE, MODIFY OR DISABLE THE FOOTSWITCH BY BLOCKING OR ANY OTHER MEANS.

WARNING

FOOTSWITCH MUST BE ADJUSTED IF FUNCTIONS ACTIVATE WHEN SWITCH ONLY OPERATES WITHIN LAST 1/4" OF TRAVEL, TOP OR BOTTOM.

NOTE: Refer to Fuel Reserve/Shut-Off System in Section 4 for more detailed information concerning the Low Fuel Indicator.

8. Fuel Level Indicator

Indicates the level of fuel in the fuel tank.

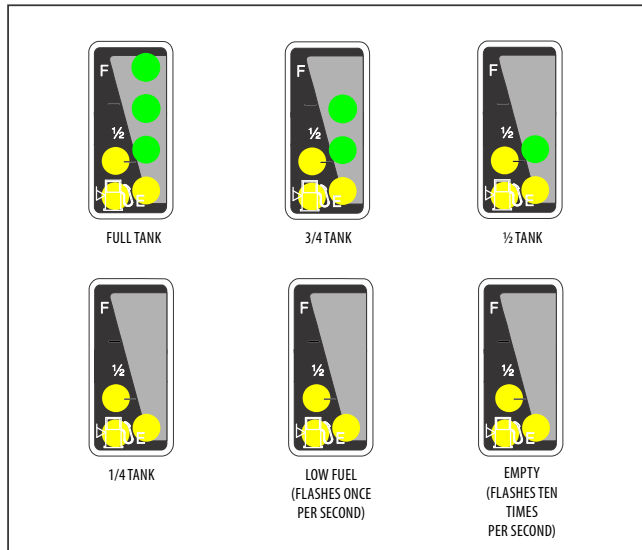

Figure 3-8. Fuel Level Indicator

9. Creep Speed Indicator

When the Function Speed Control is turned to the creep position, the indicator acts as a reminder that all functions are set to the slowest speed. The light flashes if the control system puts the machine into creep speed and will be on continuously if the operator selects creep speed.

10. System Distress Indicator

The light indicates that the JLG Control System has detected a malfunction and a Diagnostic Trouble Code has been set in the system memory. Refer to the Service Manual for instructions concerning the trouble codes and trouble code retrieval.

The malfunction indicator light will illuminate for 2-3 seconds when the key is positioned to the on position to act as a self test.

SECTION 3 - MACHINE CONTROLS AND INDICATORS

11. Cable Service Indicator

When illuminated, the light indicates the boom cables are loose or broken and must be repaired or adjusted immediately.

12. Drive Orientation Indicator

When the boom is swung beyond the rear drive tires or further in either direction, the Drive Orientation indicator will illuminate when the drive function is selected. This is a signal for the operator to verify that the drive control is being operated in the proper direction (i.e. controls reversed situations).

13. Axles Set Indicator

Indicates that the axles are fully extended. The indicator will flash as the axles are extending or retracting and be on solid when fully extended. The light will go out when the axles are fully retracted.

14. Boom Control System Warning Indicator

Indicates the platform is outside the operating area and operation of certain boom functions may be disabled (i.e. lift, telescope). Attempts to use the disabled functions cause the indicator to flash and an alarm to sound. Immediately return the platform to the ground. If the indicator remains lit, a boom control system fault or failure has been detected. If a failure is discovered, the system must be repaired by JLG authorized service personnel before the machine can be used.

SECTION 4. MACHINE OPERATION

4.1 DESCRIPTION

This machine is a self-propelled hydraulic lift equipped with a work platform on the end of an elevating and rotating boom.

The primary operator control station is in the platform. From this control station, the operator can drive and steer the machine in both forward and reverse directions. The operator can raise or lower the upper or lower boom or swing the boom to the left or right. Standard boom swing is 360 degree continuous left and right of the stowed position. The machine has a Ground Control Station which will override the Platform Control Station. Ground Controls operate Boom Lift and Swing, and are to be used in an emergency to lower the platform to the ground should the operator in the platform be unable to do so.

4.2 BOOM OPERATING CHARACTERISTICS AND LIMITATIONS

Capacities

The boom can be raised more than 15° above horizontal with or without any load in platform, if:

1. Machine is positioned on a smooth, firm and level surface.
2. Axles are extended.
3. Load is within manufacturer's rated capacity.
4. All machine systems are functioning properly.
5. Proper tire pressure.
6. Machine is as originally equipped from JLG.

Controlled Arc

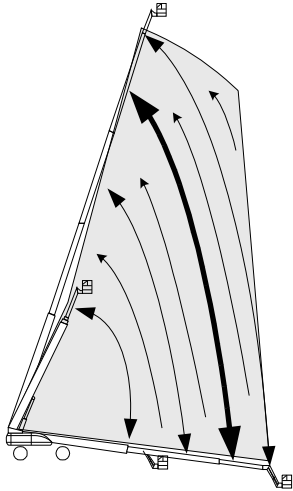

Controlled Arc Boom Movement

When the Boom Control Select switch is in the automatic mode, the boom control system automatically controls lift and telescope when the lift function is selected to move the platform through a predetermined arc, equivalent to the percentage of extension. (i.e. If you start at 70% boom extension, you will end up at approximately 70% boom extension no matter where you stop in the arc). This means that when lifting down, telescope in

will function automatically, or when lifting up, telescope out will function automatically.

When the Boom Control Switch is in the manual mode, lift and telescope functions are independent functions controlled by the operator.

Envelope Tracking

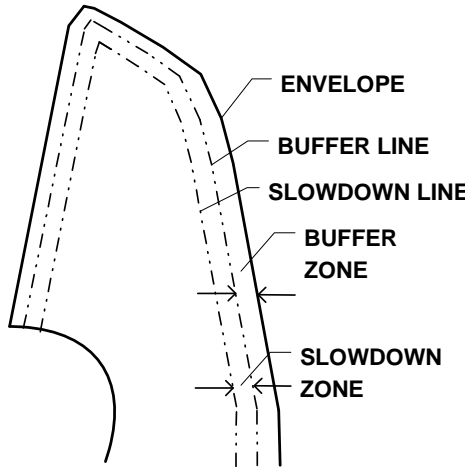

When the platform approaches the edges of the operating envelope all machine functions are slowed down automatically by the boom control system to reduce machine motions.

NOTE: *Boom Control System in Automatic Mode: When the boom is completely elevated along the edge of the backward stability region and the telescope in function is activated, lift down will automatically function until the boom is away from the edge of the backward stability region.*

Boom Control System in Manual Mode: The boom will stop when the end of the envelope is reached and the operator must activate lift and/or telescope in the proper direction to bring the boom back into the envelope.

Controlled Angle

The control system automatically maintains a constant elevated boom angle when swinging the turntable. If the boom angle is at 30 degrees, swing engaged by its self shall add lift to maintain the relative boom angle at 30 degrees.

Swing Speed Proportioning

The boom control system sensors sense the distance the platform is extended from the turntable, allowing higher swing speeds with the boom retracted and gradually slower swing speeds as the boom is extended.

Stability

Machine stability is based on two (2) conditions which are called FORWARD and BACKWARD stability. The machine's position of least FORWARD stability is shown in (See Figure 4-1.), and its position of least BACKWARD stability is shown in (See Figure 4-2.)

WARNING

TO AVOID FORWARD OR BACKWARD TIPPING, DO NOT OVERLOAD MACHINE OR OPERATE THE MACHINE ON AN OUT-OF-LEVEL SURFACE.

4.3 CAPACITY SELECT

The Boom Control System allows the operator to select operation in a 500 lb. (227 kg for ANSI markets and 230 kg for CE and Australia markets) capacity restriction envelope or a 1000 lb. (454 kg for ANSI markets and 450 kg for CE and Australia markets) capacity restriction envelope. The operator selects the desired capacity restriction by positioning the Capacity Select switch on the platform console. The Capacity Indicator shows the capacity selected, and both capacity lights will flash and an alarm sound if the platform is out of the selected capacity range.

NOTE: *Operation in the 1000 lb. (454 kg for ANSI markets and 450 kg for CE and Australia markets) envelope requires the jib to be fixed in the centered position.*

4.4 ENGINE OPERATION

NOTE: *Initial starting should always be performed from the Ground Control station.*

Starting Procedure

⚠ CAUTION

IF ENGINE FAILS TO START PROMPTLY, DO NOT CRANK FOR AN EXTENDED TIME. SHOULD ENGINE FAIL TO START AGAIN, ALLOW STARTER TO “COOL OFF” FOR 2-3 MINUTES. IF ENGINE FAILS AFTER SEVERAL ATTEMPTS, REFER TO ENGINE MAINTENANCE MANUAL.

NOTE: *Diesel engines only: After turning on ignition, operator must wait until glow plug indicator light goes out before cranking engine.*

1. Turn key of SELECT switch to GROUND. Position POWER/EMERGENCY STOP switch to ON, then push the ENGINE START switch until engine starts.

⚠ CAUTION

ALLOW ENGINE TO WARM-UP FOR A FEW MINUTES AT LOW SPEED BEFORE APPLYING ANY LOAD.

2. After engine has had sufficient time to warm up, shut engine off.

3. Turn SELECT switch to PLATFORM.
4. From Platform, pull POWER/EMERGENCY STOP switch out, then push the ENGINE START switch until engine starts.

NOTE: *Footswitch must be in released (up) position before starter will operate. If starter operates with footswitch in the depressed position, DO NOT OPERATE MACHINE.*

Shutdown Procedure

⚠ CAUTION

IF AN ENGINE MALFUNCTION CAUSES AN UNSCHEDULED SHUTDOWN, DETERMINE THE CAUSE AND CORRECT IT BEFORE RESTARTING THE ENGINE.

1. Remove all load and allow engine to operate at low speed for 3-5 minutes; this allows further reduction of internal engine temperature.
2. Push POWER/EMERGENCY STOP switch in.
3. Turn MASTER switch to Off.

Refer to Engine Manufacturer's manual for detailed information.

Fuel Reserve / Shut-Off System

NOTE: Reference the Service and Maintenance Manual along with a qualified JLG Mechanic to verify your machine setup.

The Fuel Shutoff System monitors the fuel in the tank and senses when the fuel level is getting low. The JLG Control System automatically shuts the engine down before the fuel tank is emptied unless the machine is set up for Engine Restart.

If fuel level reaches the Low Fuel range the $\frac{1}{4}$ tank indicator will flash once a second and there will be approximately 5 minutes of engine run time left. If the system is in this condition and automatically shuts down the engine, or the engine is manually shut down before the 5 minute run time is complete, the $\frac{1}{4}$ tank indicator will flash 10 times a second and the engine will react according to machine setup. Setup options are as follows:

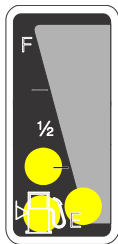

- Engine One Restart - When the engine shuts down, the operator will be permitted to cycle power and restart the engine once with approximately 2 minutes of run time. After the 2 minute run time is complete or if the engine is shut down by the operator prior to the completion of the 2 minute run time, it cannot be restarted until fuel is added to the tank.

- Engine Restart - When the engine shuts down, the operator will be permitted to cycle power and restart the engine for approximately 2 minutes of run time. After the 2 minutes of run time is complete, the operator may cycle power and restart the engine for an additional 2 minutes of run time. The operator can repeat this process until there is no more fuel available.

NOTICE

CONTACT A QUALIFIED JLG MECHANIC IF THE MACHINE NEEDS RESTARTED AFTER NO MORE FUEL IS AVAILABLE.

- Engine Stop - The engine will shut down. No restarts will be permitted until fuel is added to the tank.

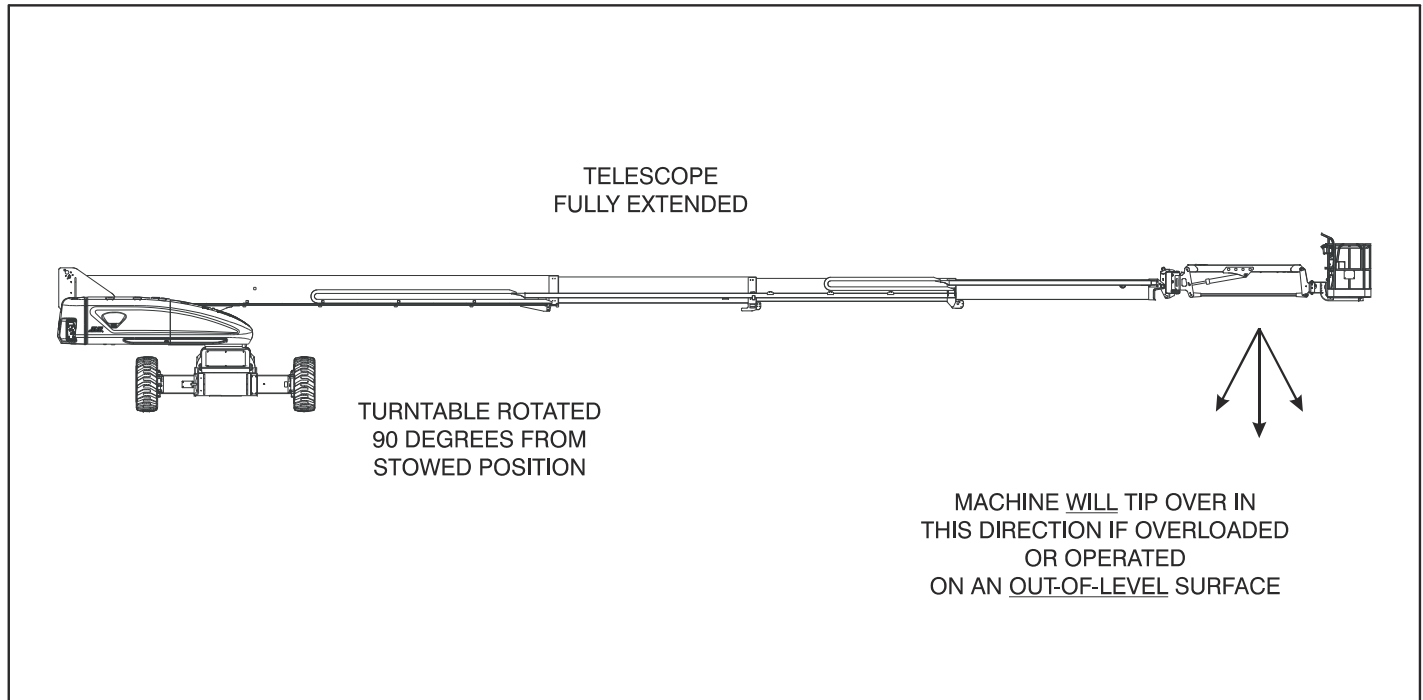

Figure 4-1. Position of Least Forward Stability

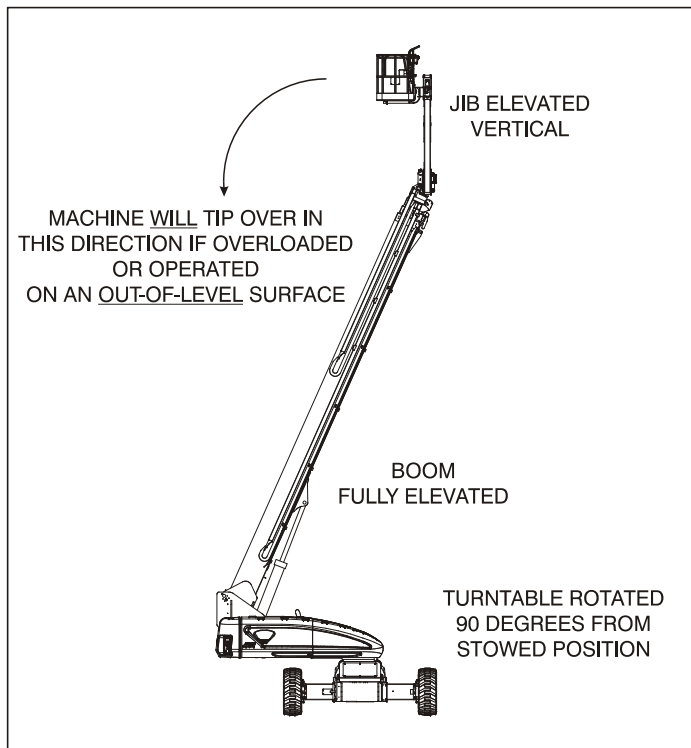

Figure 4-2. Position of Least Backward Stability

4.5 TRAVELING (DRIVING)

NOTE: When the upper boom is raised approximately 15 degrees above horizontal, the high drive function will automatically be in low drive.

⚠ WARNING

DO NOT DRIVE WITH BOOM ABOVE HORIZONTAL EXCEPT ON A SMOOTH, FIRM AND LEVEL SURFACE.

TO AVOID LOSS OF TRAVEL CONTROL OR "TIP OVER", DO NOT DRIVE MACHINE ON GRADES EXCEEDING THOSE SPECIFIED ON THE SERIAL NUMBER PLATE.

DO NOT DRIVE ON SIDESLOPES WHICH EXCEED 5 DEGREES.

USE EXTREME CAUTION WHEN DRIVING IN REVERSE AND AT ALL TIMES WHEN THE PLATFORM IS ELEVATED.

BEFORE DRIVING, LOCATE THE BLACK/WHITE ORIENTATION ARROWS ON BOTH THE CHASSIS AND THE PLATFORM CONTROLS. MOVE THE DRIVE CONTROLS IN A DIRECTION MATCHING THE DIRECTIONAL ARROWS.

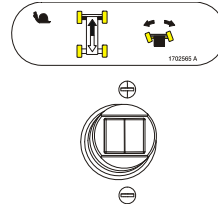
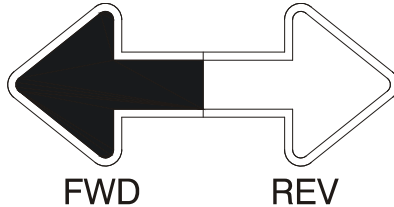

1. Match the black and white direction arrows on both platform control panel and the chassis to determine the direction the machine will travel.
2. Push and release the Drive Orientation Override switch. Within 3 seconds, slowly move the Drive control toward the arrow matching the intended direction of machine travel. The indicator light will flash during the 3 second interval until the drive function is selected.

4.6 STEERING

Position thumb switch on Drive/Steer controller to RIGHT for steering right, or to LEFT for steering left.

4.7 EXTENDING THE AXLES

NOTE: *The operator must be driving the machine (forward or reverse) in order to extend the axles.*

Position the Axle Extend switch to extend the axles or to retract the axles.

Traveling Forward and Reverse

1. At Platform Controls, pull out Emergency Stop switch, start engine, and activate footswitch.
2. Position Drive controller to FORWARD or REVERSE as desired.

This machine is equipped with a Drive Orientation Indicator. The yellow light on the platform control console indicates that the boom is swung beyond the rear drive tires and the machine may Drive/Steer in the opposite direction from the movement of the controls. If the indicator is illuminated, operate the Drive function in the following manner:

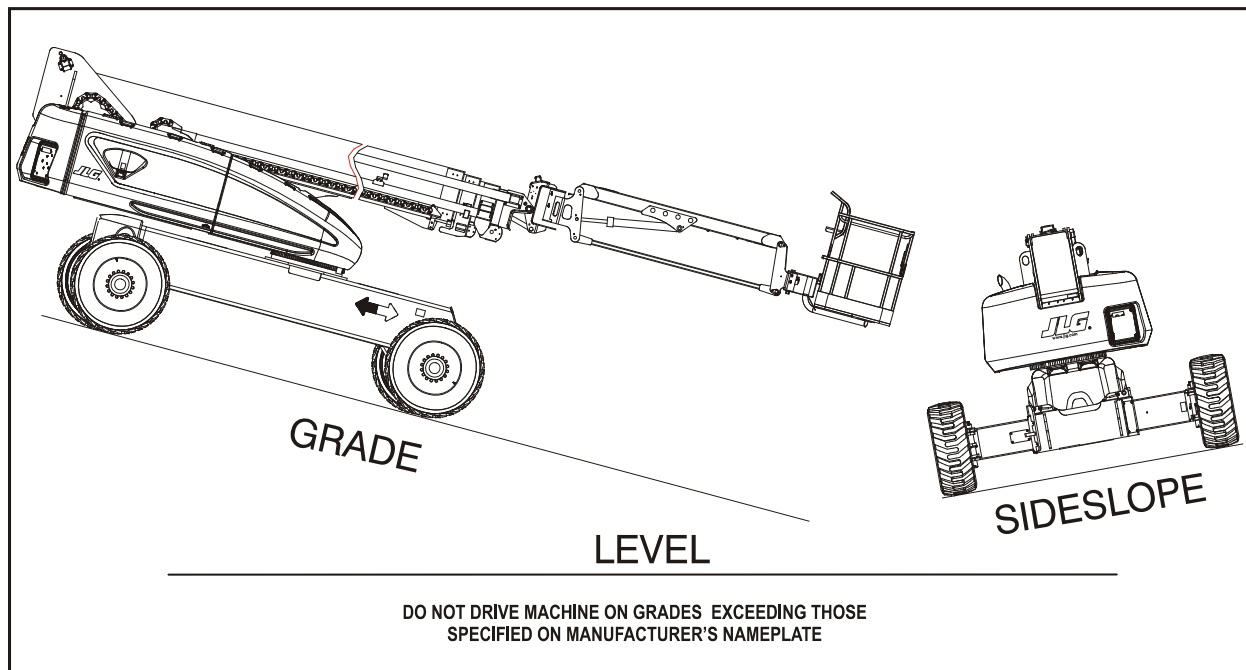

Figure 4-3. Grade and Side Slopes

4.8 PLATFORM

Platform Level Adjustment

WARNING

ONLY USE THE PLATFORM LEVELING OVERRIDE FUNCTION FOR SLIGHT LEVELING OF THE PLATFORM. INCORRECT USE COULD CAUSE THE LOAD/OCCUPANTS TO SHIFT OR FALL. FAILURE TO DO SO COULD RESULT IN DEATH OR SERIOUS INJURY.

NOTE: *When the Boom Control Select Switch is in the Manual mode, Platform leveling only functions during Main Lift operation. When the Boom Control Select Switch is in the Automatic mode, Platform Leveling is active during all functions except during telescope operation. Also, when in the Manual mode, the Controlled Angle system is not active.*

During normal operation of the machine, the platform will automatically maintain its position. To manually Level Up or Down - Position the Platform/Level control switch Up or Down and hold until the desired platform position is obtained.

Platform Rotation

To rotate the platform to the left or right, use the Platform Rotate control switch to select the direction and hold until desired position is reached.

4.9 BOOM

WARNING

DO NOT SWING OR RAISE BOOM ABOVE HORIZONTAL WHEN MACHINE IS OUT OF LEVEL.

DO NOT DEPEND ON TILT ALARM AS A LEVEL INDICATOR FOR THE CHASSIS.

TO AVOID TIP OVER, LOWER PLATFORM TO GROUND LEVEL. THEN DRIVE MACHINE TO A LEVEL SURFACE BEFORE RAISING BOOM.

TO AVOID SERIOUS INJURY, DO NOT OPERATE MACHINE IF ANY CONTROL LEVER OR TOGGLE SWITCH CONTROLLING PLATFORM MOVEMENT DOES NOT RETURN TO THE 'OFF' OR NEUTRAL POSITION WHEN RELEASED.

IF THE PLATFORM DOES NOT STOP WHEN A CONTROL SWITCH OR LEVER IS RELEASED, REMOVE FOOT FROM FOOTSWITCH OR USE EMERGENCY STOP SWITCH TO STOP THE MACHINE.

Swinging the Boom

To swing boom, use Swing control to select Right or Left direction.

NOTICE

WHEN SWINGING THE BOOM MAKE SURE THERE IS AMPLE ROOM FOR THE BOOM TO CLEAR SURROUNDING WALLS, PARTITIONS AND EQUIPMENT.

Raising and Lowering the Boom

NOTE: *The lift function is not operable above 15 degrees above horizontal if the axles are not fully extended.*

To raise or lower the Boom, use Boom Lift control to select Up or Down movement.

Telescoping the Boom

NOTE: *The telescope function is not operable beyond the transport position if the axles are not fully extended.*

To extend or retract the main boom, use the Telescope Control Switch to select In or Out movement.

Swinging the Jib

NOTE: *For 1000 lb. (454 kg for ANSI markets and 450 kg for CE and Australia markets) mode operation, the jib must be centered and the Jib Swing function is not operable. If the jib is out of the centered position when in this mode, the jib swing function will allow the operator to center the jib again.*

To swing the jib, use the Jib Swing control to select Right or Left direction.

4.10 FUNCTION SPEED CONTROL

This control affects the speed of all boom functions and Platform Rotate. When in the CCW maximum position, Drive is placed in creep speed.

4.11 EMERGENCY TOWING

⚠ WARNING

RUNAWAY VEHICLE/MACHINE HAZARD. MACHINE HAS NO TOWING BRAKES. TOWING VEHICLE MUST BE ABLE TO CONTROL MACHINE AT ALL TIMES. ON-HIGHWAY TOWING NOT PERMITTED. FAILURE TO FOLLOW INSTRUCTIONS COULD CAUSE SERIOUS INJURY OR DEATH.

MAXIMUM TOWING SPEED 5 M.P.H. (8 K.M.H.)

MAXIMUM TOWING GRADE 25%.

⚠ CAUTION

DO NOT TOW MACHINE WITH ENGINE OPERATING OR DRIVE HUBS ENGAGED.

1. Retract, lower and position boom in travel position; lock turntable.

2. Disconnect drive hubs by inverting disconnect cap.

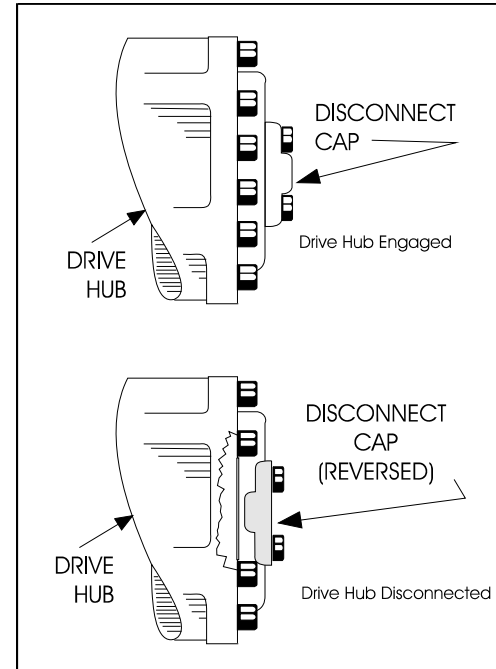

Figure 4-4. Drive Disconnect Hub

3. Reconnect the drive hubs by inverting the disconnect cap when towing is complete.

4.12 SHUT DOWN AND PARK

To shut down and park the machine, the procedures are as follows:

1. Drive machine to a reasonably well protected area.
2. Ensure boom is lowered over rear drive axle.
3. Push in the Emergency Stop at Platform Controls.
4. Push in the Emergency Stop at Ground Controls. Position Platform/Ground Select switch to center OFF.
5. If necessary, cover Platform Controls to protect instruction placards, warning decals and operating controls from hostile environment.

4.13 LIFTING AND TIE DOWN

See Figure 4-5. and Figure 4-6.

Lifting

1. Call JLG Industries or weigh the individual unit to find out the Gross Vehicle Weight.
2. Place the boom in the stowed position with the turntable locked.
3. Remove all loose items from the machine.
4. Attach lifting device and equipment only to the designated lifting points.
5. Properly adjust the rigging to prevent damage to the machine and so the machine remains level.

Tie Down

NOTICE

WHEN TRANSPORTING THE MACHINE, THE BOOM MUST BE FULLY LOWERED INTO THE BOOM REST.

NOTE: *Prior to loading the machine onto a trailer, it will be necessary to rotate the turntable 180 degrees to provide better weight distribution.*

1. Place the boom in the stowed position with the turntable locked.
2. Remove all loose items from the machine.
3. Secure the chassis and the platform using straps or chains of adequate strength and attached to the designated tie down points.

4.14 STOWING THE JIB FOR TRANSPORT

1. Place the boom in the stowed position with the axles retracted.
2. Hold the Jib Swing control switch to the right until the platform will no longer swing.

NOTE: *The Jib Swing function is not operable when the Capacity Select control is in the 1000 lb. (454 kg for ANSI markets and 450 kg for CE and Australia markets) position.*

NOTE: *Automatic platform leveling is disabled when stowing the jib.*

3. Push and hold the Jib Stow control switch until the jib and platform are in the stowed position under the boom.

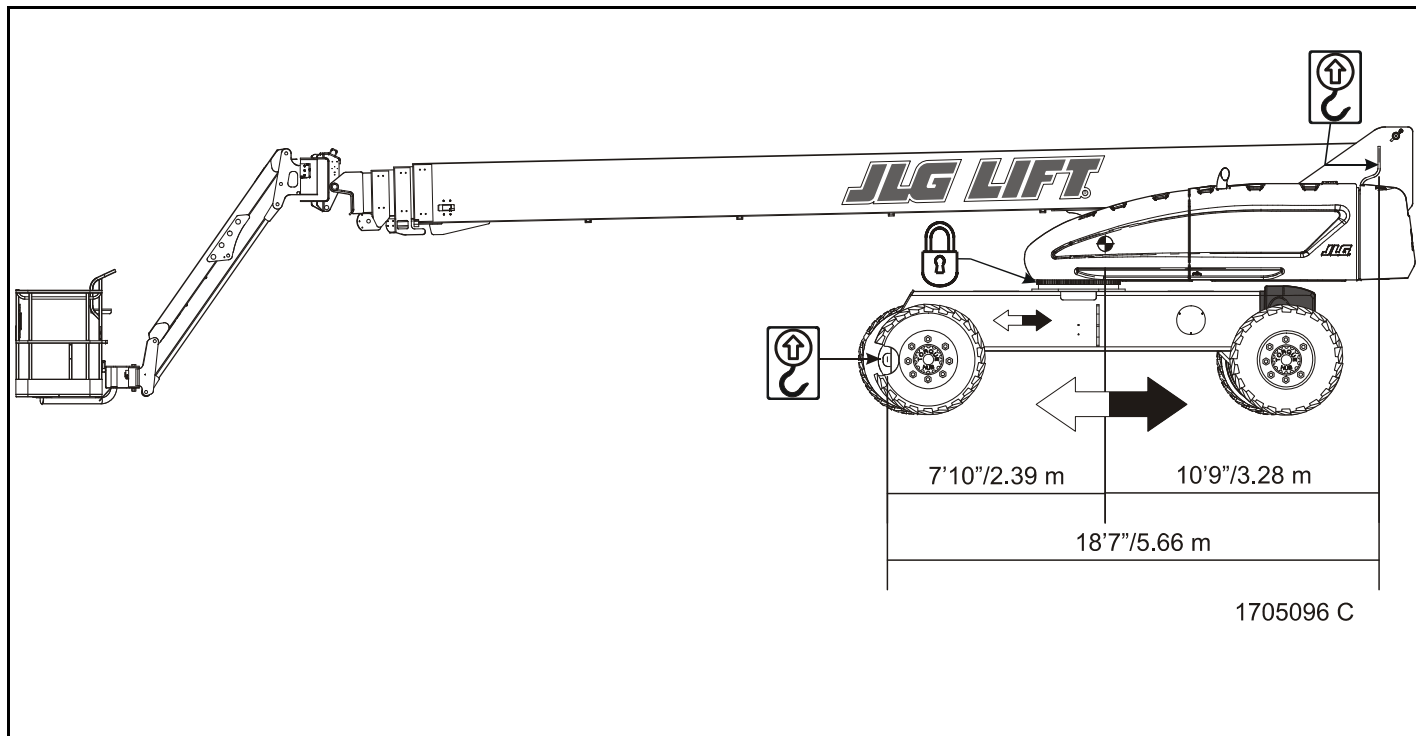

Figure 4-5. Lifting and Tie Down Chart - Sheet 1 of 2

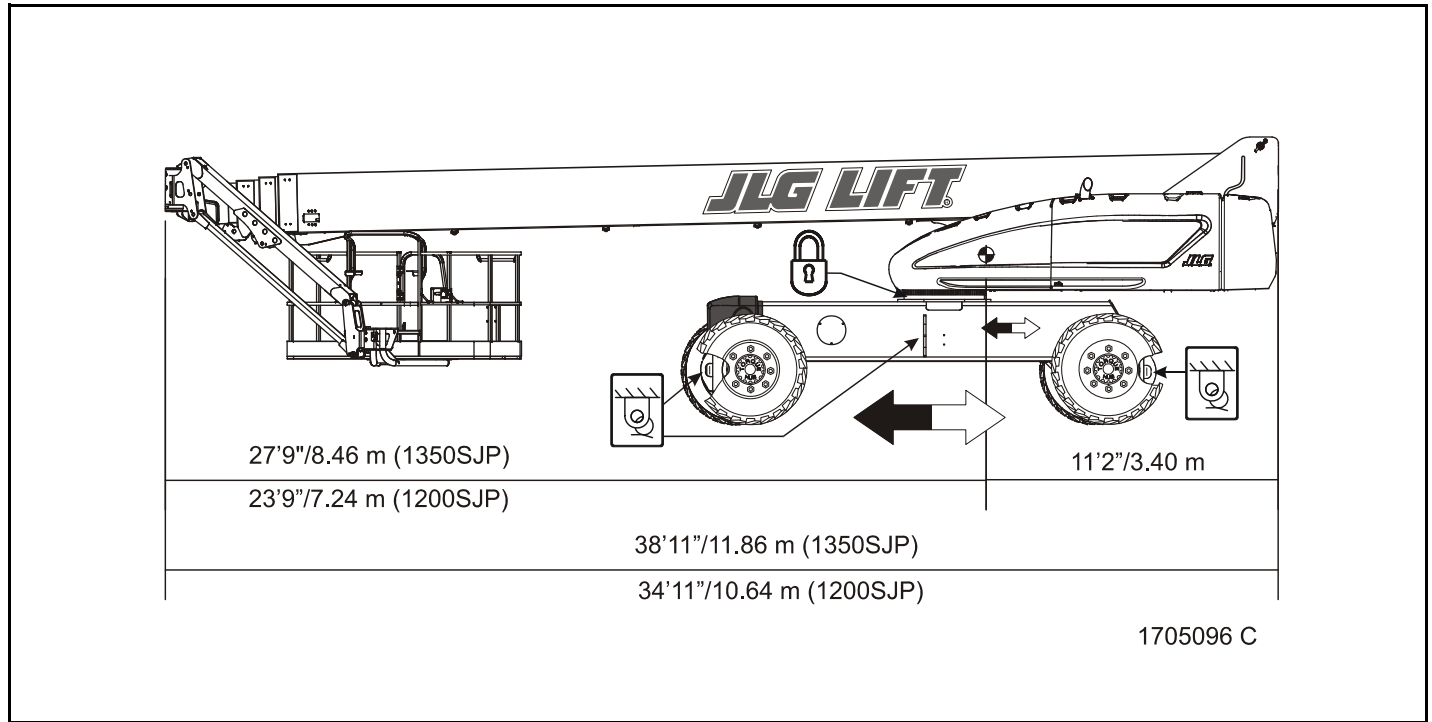

Figure 4-6. Lifting and Tie Down Chart - Sheet 2 of 2

SECTION 4 - MACHINE OPERATION

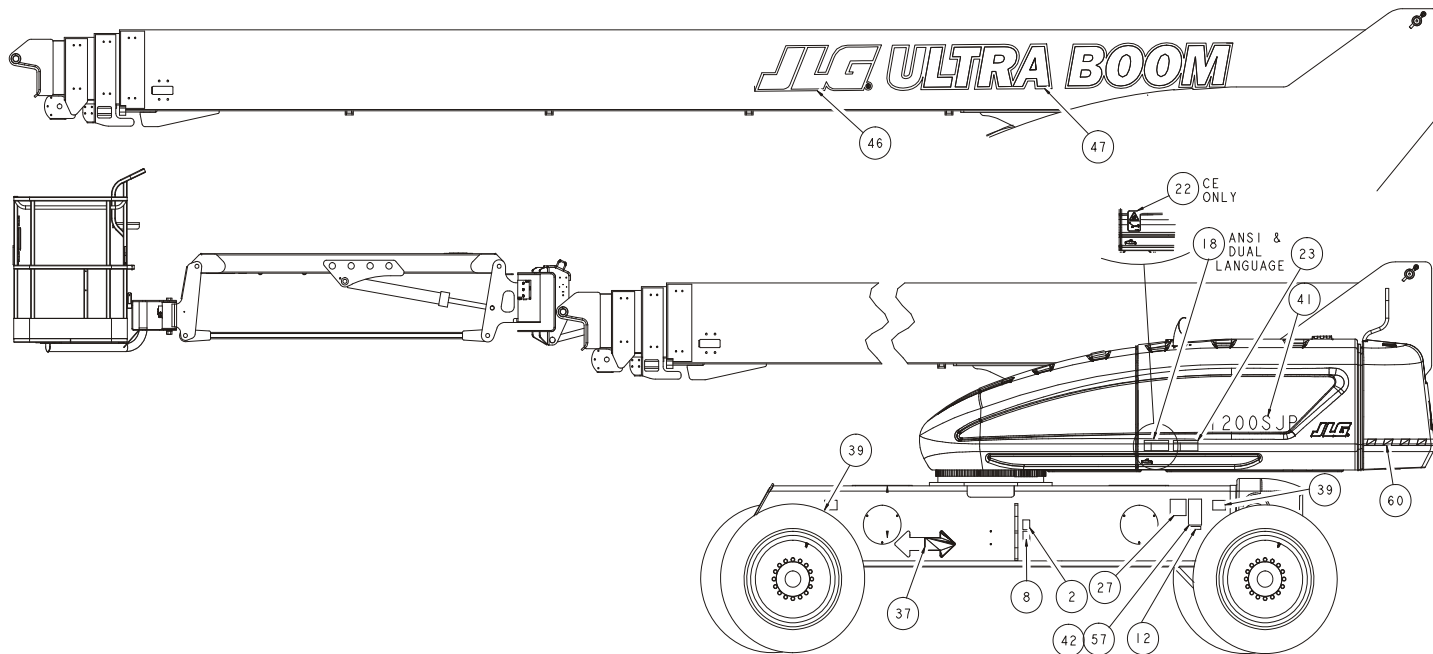

Figure 4-7. Decal Location Sheet 1 of 5

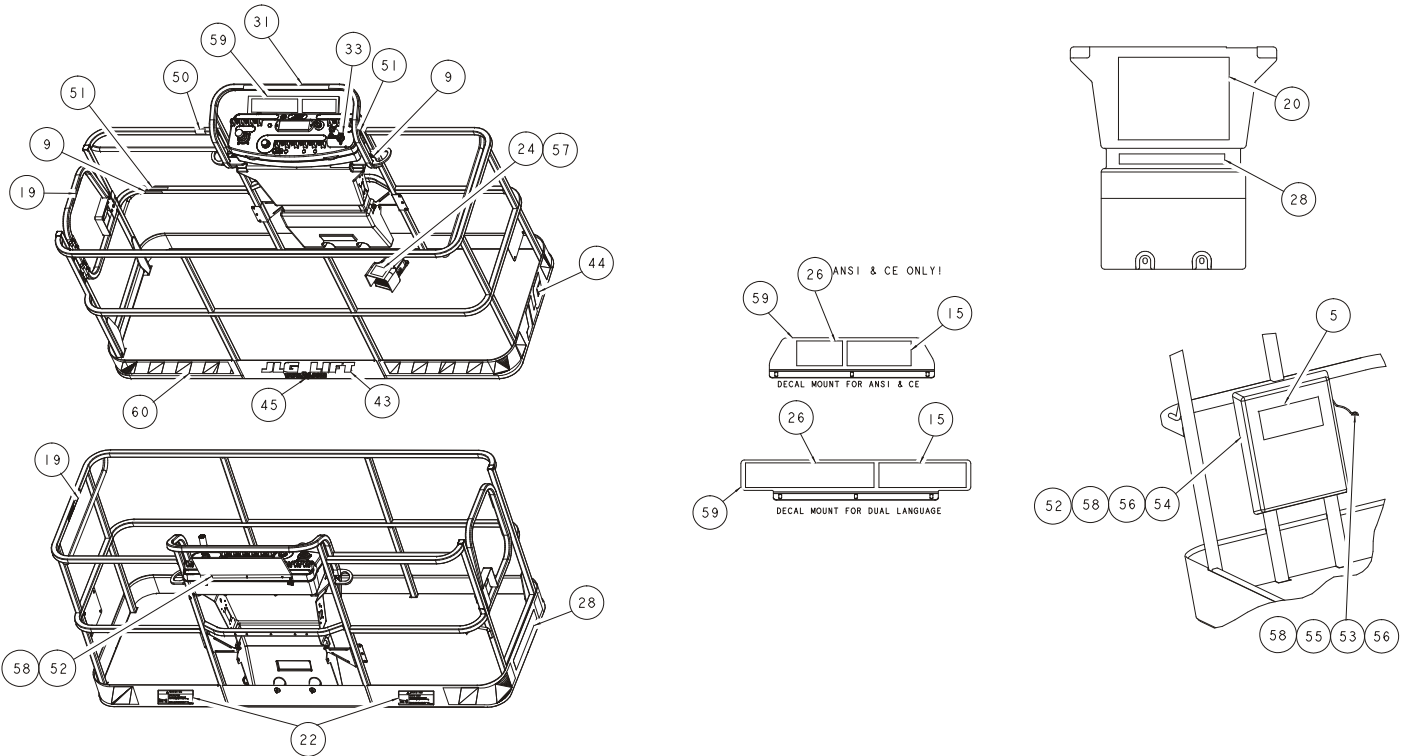

Figure 4-8. Decal Location Sheet 2 of 5

SECTION 4 - MACHINE OPERATION

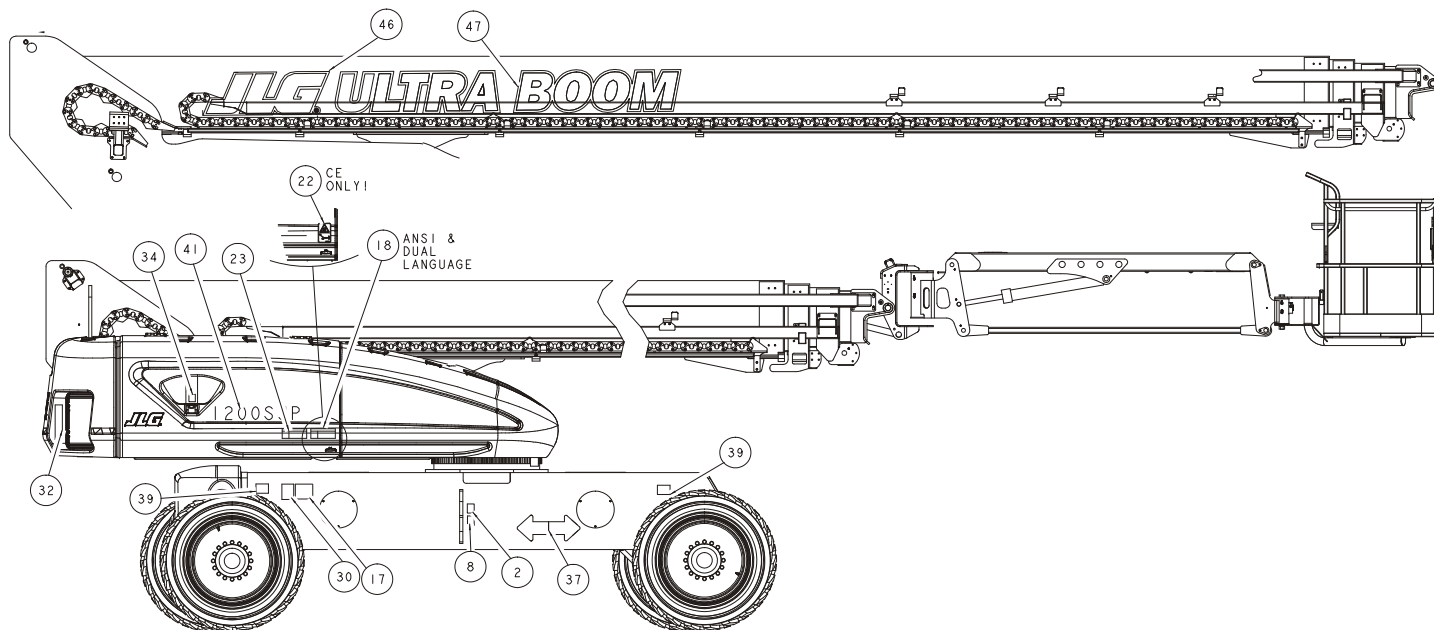

Figure 4-9. Decal Location Sheet 3 of 5

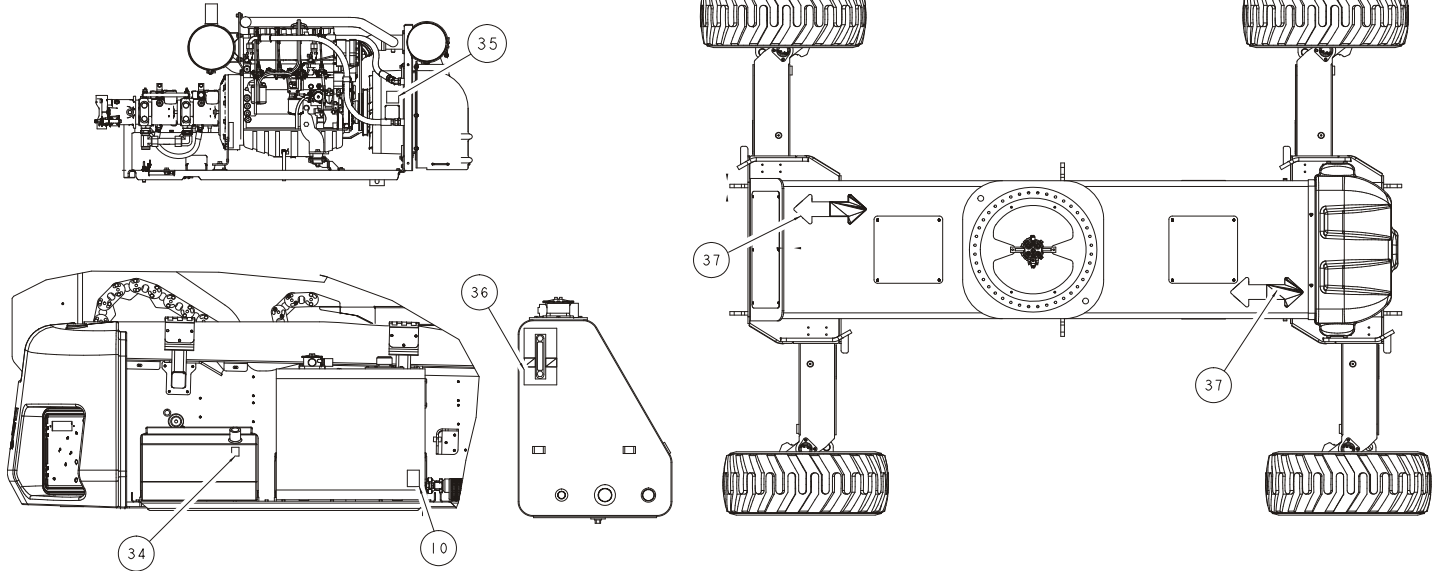

Figure 4-10. Decal Location Sheet 4 of 5

SECTION 4 - MACHINE OPERATION

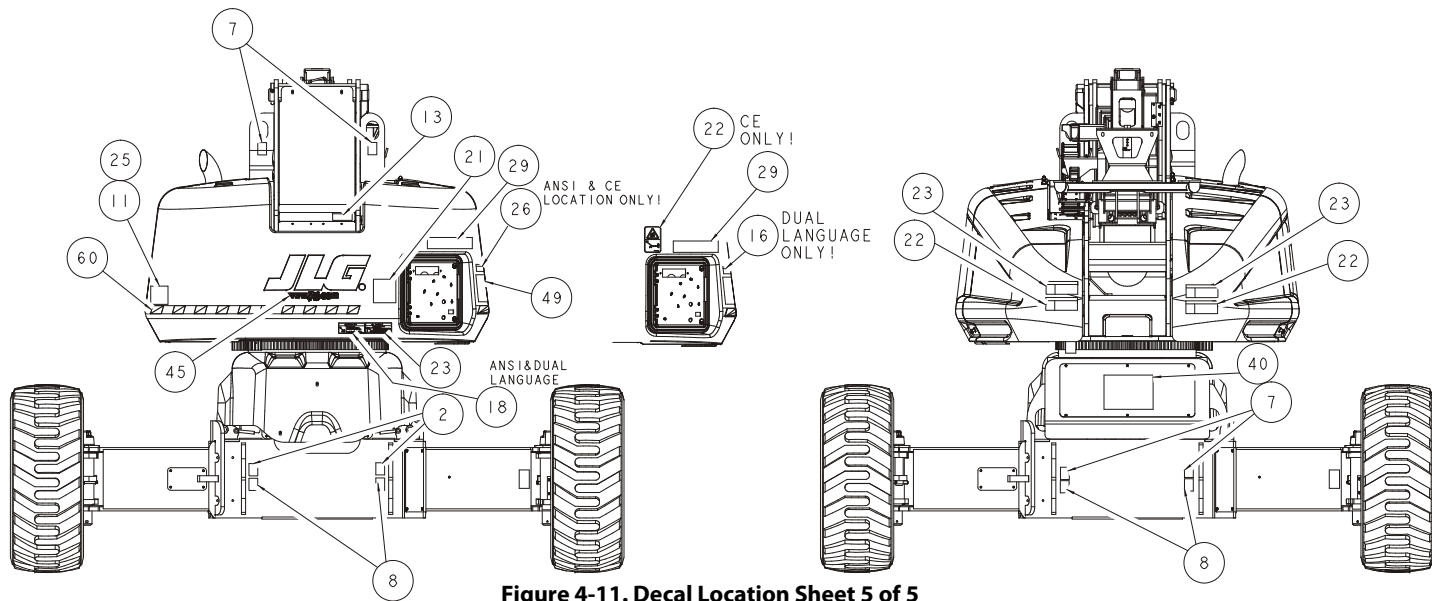

Table 4-1. Decal Legend - Prior to S/N 0300141473

Item #	ANSI 0274722-7	Korean 0274723-7	Chinese 0274724-7	Portuguese 0274725-7	English/ Spanish 0274726-8	French/English 0274727-7	CE/Australian 0274728-8	Japan 0274729-7
1	--	--	--	--	--	--	--	--
2	1701499	1701499	1701499	1701499	1701499	1701499	1701499	1701499
3	--	--	--	--	--	--	--	--
4	--	--	--	--	--	--	--	--
5	1701509	1701509	1701509	1701509	1701509	1701509	1701509	1701509
6	1701529	1701529	1701529	1701529	1701529	1701529	1701529	1701529
7	1703811	1703811	1703811	1703811	1703811	1703811	1703811	1703811
8	1703814	1703814	1703814	1703814	1703814	1703814	1703814	1703814
9	1704277	1704277	1704277	1704277	1704277	1704277	1704277	1704277
10	1704412	1704412	1704412	1704412	1704412	1704412	1704412	1704412
11	--	--	--	--	--	--	1705515	--
12	--	--	--	--	--	1705514	--	--
13	3251243	3251243	3251243	3251243	3251243	3251243	--	3251243
14	--	--	--	--	--	--	--	--
15	1705337	1705337	1705342	1705904	1705337	1705341	--	1705338
16	--	--	1705507	1705906	1705916	1705505	--	1705493

SECTION 4 - MACHINE OPERATION

Table 4-1. Decal Legend - Prior to S/N 0300141473

Item #	ANSI 0274722-7	Korean 0274723-7	Chinese 0274724-7	Portuguese 0274725-7	English/ Spanish 0274726-8	French/English 0274727-7	CE/Australian 0274728-8	Japan 0274729-7
17	--	1702153	--	1705901	1704007	1704006	--	--
18	1703953	1703953	1703943	1705903	1703941	1703942	--	1703944
19	1702868	1702868	1705968	1705967	1704001	1704000	--	--
20	1703797	1703797	1703925	1705895	1703923	1703924	1705921	1703926
21	1705336	1705336	1705348	1705896	1705917	1705347	1705822	1705344
22	1703804	1703804	1703949	1705898	1703947	1703948	1701518	1703950
23	1703805	1703805	1703937	1705897	1703935	1703936	1705961	1703938
24	3252347	--	1703982	1705902	1703983	1703984	1705828	1703980
25	3251813	3251813	3251813	3251813	3251813	3251813	--	3251813
26	1705492	1705492	1705508	1705907	1705915	1705506	--	1705494
27	1702631	1702631	1702631	1702631	1702631	1702631	1702631	1702631
28	1705168	1705168	1705334	1705899	1705908	1705333	1706770	1705330
29	1705181	1705181	1705478	1705900	1705919	1705477	1705468	1705480
30	1700584	1700584	1700584	1700584	1700584	1700584	1700584	1700584
31	1706751	1706751	1706751	1706751	1706751	1706751	--	1706751
32	1705868	1705868	1705868	1705868	1705868	1705868	--	1705868
33	1705351	1705351	1705430	1705905	1705910	1705429	--	1705426
34	1701505	1701505	1701505	1701505	1701505	1701505	1701505	1701505

Table 4-1. Decal Legend - Prior to S/N 0300141473

Item #	ANSI 0274722-7	Korean 0274723-7	Chinese 0274724-7	Portuguese 0274725-7	English/ Spanish 0274726-8	French/English 0274727-7	CE/Australian 0274728-8	Japan 0274729-7
35	1704972	1704972	1706060	1706059	1706063	1706064	1706098	1704972
36	1705511	1705511	1705511	1705511	1705511	1705511	1705511	1705511
37	1701501	1701501	1701501	1701501	1701501	1701501	1701501	1701501
38	--	--	--	--	--	--	--	--
39	--	--	--	--	--	--	--	--
40	--	--	--	--	--	--	--	--
41	--	--	--	--	--	--	--	--
42	--	--	--	--	--	--	--	--
43	--	--	--	--	--	--	--	--
44	--	--	--	--	--	--	--	--
45	--	--	--	--	--	--	--	--
46	--	--	--	--	--	--	--	--
47	--	--	--	--	--	--	--	--
48	--	--	--	--	--	--	--	--
49	--	--	--	--	--	--	--	--
50	--	--	--	--	--	--	--	--
51	--	--	--	--	--	--	--	--
52	--	--	--	--	--	--	--	--

SECTION 4 - MACHINE OPERATION

Table 4-1. Decal Legend - Prior to S/N 0300141473

Item #	ANSI 0274722-7	Korean 0274723-7	Chinese 0274724-7	Portuguese 0274725-7	English/ Spanish 0274726-8	French/English 0274727-7	CE/Australian 0274728-8	Japan 0274729-7
53	--	--	--	--	--	--	--	--
54	--	--	--	--	--	--	--	--
55	--	--	--	--	--	--	--	--
56	--	--	--	--	--	--	--	--
57	--	--	--	--	--	--	--	--
58	--	--	--	--	--	--	--	--
59	--	--	--	--	--	--	--	--
60	--	--	--	--	--	--	--	--

Table 4-2. Decal Legend - S/N 0300141473 to Present

Item #	ANSI 0274722-B	Korean 0274723-B	Chinese 0274724-B	Portuguese 0274725-B	English/ Spanish 0274726-B	French/English 0274727-B	CE/Australian 0274728-B	Japan 0274729-B
1	--	--	--	--	--	--	--	--
2	1701499	1701499	1701499	1701499	1701499	1701499	1701499	1701499
3	--	--	--	--	--	--	--	--
4	--	--	--	--	--	--	--	--
5	1701509	1701509	1701509	1701509	1701509	1701509	1701509	1701509
6	1701529	1701529	1701529	1701529	1701529	1701529	1701529	1701529
7	1703811	1703811	1703811	1703811	1703811	1703811	1703811	1703811
8	1703814	1703814	1703814	1703814	1703814	1703814	1703814	1703814
9	1704277	1704277	1704277	1704277	1704277	1704277	1704277	1704277
10	1704412	1704412	1704412	1704412	1704412	1704412	1704412	1704412
11	--	--	--	--	--	--	1705515	--
12	--	--	--	--	--	1705514	--	--
13	3251243	3251243	3251243	3251243	3251243	3251243	--	3251243
14	--	--	--	--	--	--	--	--
15	1705337	1705337	1705342	1705904	1705337	1705341	--	1705338
16	--	--	1001117035	1705906	1705916	1705505	--	1705493

SECTION 4 - MACHINE OPERATION

Table 4-2. Decal Legend - S/N 0300141473 to Present

Item #	ANSI 0274722-B	Korean 0274723-B	Chinese 0274724-B	Portuguese 0274725-B	English/ Spanish 0274726-B	French/English 0274727-B	CE/Australian 0274728-B	Japan 0274729-B
17	--	1702153	--	--	--	--	--	--
18	1703953	1703953	1703943	1705903	1703941	1703942	--	1703944
19	1702868	1702868	1001116846	1705967	1704001	1704000	--	--
20	1703797	1703797	1703925	1705895	1703923	1703924	1705921	1703926
21	1705336	1705336	1001116849	1705896	1705917	1705347	1705822	1705344
22	1703804	1703804	1703949	1705898	1703947	1703948	1701518	1703950
23	1703805	1703805	1001116851	1705897	1703935	1703936	1705961	1703938
24	3252347	--	1703982	1705902	1703983	1703984	1705828	1703980
25	--	--	--	--	--	--	--	--
26	1705492	1705492	1705508	1705907	1705915	1705506	--	1705494
27	1702631	1702631	1702631	1702631	1702631	1702631	1702631	1702631
28	1001122369	1001122370	1001122371	1001122372	1001122373	1001122374	1706770	1001122375
29	1001122376	1001122377	1001122378	1001122379	1001122380	1001122381	1705468	1001122382
30	1001131269	--	--	--	--	1700584	--	--
31	1706751	1706751	1706751	1706751	1706751	1706751	--	1706751
32	1705868	1705868	1705868	1705868	1705868	1705868	--	1705868
33	1705351	1705351	1705430	1705905	1705910	1705429	--	1705426
34	1701505	1701505	1701505	1701505	1701505	1701505	1701505	1701505

Table 4-2. Decal Legend - S/N 0300141473 to Present

Item #	ANSI 0274722-B	Korean 0274723-B	Chinese 0274724-B	Portuguese 0274725-B	English/ Spanish 0274726-B	French/English 0274727-B	CE/Australian 0274728-B	Japan 0274729-B
35	1704972	1704972	1706060	1706059	1706063	1706064	1706098	1704972
36	1705511	1705511	1705511	1705511	1705511	1705511	1705511	1705511
37	1701501	1701501	1701501	1701501	1701501	1701501	1701501	1701501
38	--	--	--	--	--	--	--	--
39	--	--	--	--	--	--	--	--
40	--	--	--	--	--	--	--	--
41	--	--	--	--	--	--	--	--
42	--	--	--	--	--	--	--	--
43	--	--	--	--	--	--	--	--
44	--	--	--	--	--	--	--	--
45	--	--	--	--	--	--	--	--
46	--	--	--	--	--	--	--	--
47	--	--	--	--	--	--	--	--
48	--	--	--	--	--	--	--	--
49	--	--	--	--	--	--	--	--
50	--	--	--	--	--	--	--	--
51	--	--	--	--	--	--	--	--
52	--	--	--	--	--	--	--	--

SECTION 4 - MACHINE OPERATION

Table 4-2. Decal Legend - S/N 0300141473 to Present

Item #	ANSI 0274722-B	Korean 0274723-B	Chinese 0274724-B	Portuguese 0274725-B	English/ Spanish 0274726-B	French/English 0274727-B	CE/Australian 0274728-B	Japan 0274729-B
53	--	--	--	--	--	--	--	--
54	--	--	--	--	--	--	--	--
55	--	--	--	--	--	--	--	--
56	--	--	--	--	--	--	--	--
57	--	--	--	--	--	--	--	--
58	--	--	--	--	--	--	--	--
59	--	--	--	--	--	--	--	--
60	--	--	--	--	--	--	--	--

SECTION 5. EMERGENCY PROCEDURES

5.1 GENERAL

This section explains the steps to be taken in case of an emergency situation while operating.

5.2 INCIDENT NOTIFICATION

JLG Industries, Inc. must be notified immediately of any incident involving a JLG product. Even if no injury or property damage is evident, the factory should be contacted by telephone and provided with all necessary details.

In USA:

JLG Phone: 877-JLG-SAFE (554-7233)
(8am till 4:45pm EST)

Outside USA:

240-420-2661

E-mail:

ProductSafety@JLG.com

Failure to notify the manufacturer of an incident involving a JLG Industries product within 48 hours of such an occurrence may void any warranty consideration on that particular machine.

NOTICE

FOLLOWING ANY ACCIDENT, THOROUGHLY INSPECT THE MACHINE AND TEST ALL FUNCTIONS FIRST FROM THE GROUND CONTROLS, THEN FROM THE PLATFORM CONTROLS. DO NOT LIFT ABOVE 3 M (10 FT.) UNTIL YOU ARE SURE THAT ALL DAMAGE HAS BEEN REPAIRED, IF REQUIRED, AND THAT ALL CONTROLS ARE OPERATING CORRECTLY.

5.3 EMERGENCY OPERATION

Operator Unable to Control Machine

IF THE PLATFORM OPERATOR IS PINNED, TRAPPED OR UNABLE TO OPERATE OR CONTROL MACHINE:

1. Other personnel should operate the machine from ground controls only as required.
2. Other qualified personnel on the platform may use the platform controls. DO NOT CONTINUE OPERATION IF CONTROLS DO NOT FUNCTION PROPERLY.
3. Cranes, forklift trucks or other equipment can be used to remove platform occupants and stabilize motion of the machine.

Platform or Boom Caught Overhead

If the platform or boom becomes jammed or snagged in overhead structures or equipment, rescue platform occupants prior to freeing the machine.

Boom Movement Prevented By Boom Control System

Lowering the boom onto an object or structure, with the boom at high angles, may cause the boom control system to prevent movement of the machine. This can include movement necessary to lift the boom off the object. Movement of the boom can be regained by observing the following:

1. Shut off the engine.
2. Rescue platform occupants prior to freeing machine.
3. Use cranes, forklifts or other equipment to stabilize motion of the machine as required.
4. From the ground control position, use the Auxiliary Power System to carefully raise the boom off the object.
5. Once clear, restart the engine and return the platform to the ground.
6. Inspect the machine for damage before continued use of the machine.

5.4 EMERGENCY TOWING PROCEDURES

Towing this machine is prohibited, unless properly equipped. However, provisions for moving the machine have been incorporated. For specific procedures, refer to Section 4.

SECTION 6. GENERAL SPECIFICATIONS & OPERATOR MAINTENANCE

6.1 INTRODUCTION

This section of the manual provides additional necessary information to the operator for proper operation and maintenance of this machine.

The maintenance portion of this section is intended as information to assist the machine operator to perform daily maintenance tasks only, and does not replace the more thorough Preventive Maintenance and Inspection Schedule included in the Service and Maintenance Manual.

Other Publications Available:

Service and Maintenance Manual3121142
 Illustrated Parts Manual3121208

6.2 OPERATING SPECIFICATIONS

Table 6-1. Operating Specifications - Prior to S/N 0300141473

Maximum Work Load (Capacity)	
Unrestricted	500 lb (230 kg)
Restricted	1000 lb. (450 kg)
Max. Vertical Platform Height (Unrestricted)	
1200SJP	120 ft. (36.6 m)
1350SJP	135 ft. (41.2 m)
Max. Vertical Platform Height (Restricted)	
1200SJP	115 ft. (35.1 m)
1350SJP	125 ft. (38.1 m)
Max. Horizontal Platform Reach (Unrestricted)	
1200SJP	75 ft. (22.9 m)
1350SJP	80 ft. (24.4 m)
Max. Horizontal Platform Reach (Restricted)	
1200SJP	65 ft. (19.8 m)
1350SJP	70 ft. (21.3 m)
JibPLUS	
Length	8ft. (2.44m)
Horizontal Motion	180° working, 244° stowed
Vertical Motion	130° (+75/-55)

SECTION 6 - GENERAL SPECIFICATIONS & OPERATOR MAINTENANCE

Table 6-2. Operating Specifications - S/N 0300141473 to Present

Maximum Work Load (Capacity) - ANSI Unrestricted Restricted	500 lb (227 kg) 1000 lb. (454 kg)
Maximum Work Load (Capacity)- CE & Australia Unrestricted Restricted	500 lb (230 kg) 1000 lb. (450 kg)
Max. Vertical Platform Height (Unrestricted) 1200SJP 1350SJP	120 ft. (36.6 m) 135 ft. (41.2 m)
Max. Vertical Platform Height (Restricted) 1200SJP 1350SJP	115 ft. (35.1 m) 125 ft. (38.1 m)
Max. Horizontal Platform Reach (Unrestricted) 1200SJP 1350SJP	75 ft. (22.9 m) 80 ft. (24.4 m)
Max. Horizontal Platform Reach (Restricted) 1200SJP 1350SJP	65 ft. (19.8 m) 70 ft. (21.3 m)
JibPLUS Length Horizontal Motion Vertical Motion	8ft. (2.44m) 180° working, 244° stowed 130° (+75/-55)

Dimensional Data

Table 6-3. Dimensional Data

Overall Width Axles Retracted Axles Extended	8ft. 2in. (2.49 m) 12ft. 6in. (3.8 m)
Stowed Height	10ft. (3.04 m)
Stowed Length (Transport Mode) 1200SJP 1350SJP	34ft. 11in. (10.64 m) 38ft. 11in. (11.86 m)
Stowed Length (Working Mode) 1200SJP 1350SJP	44ft. 11in. (13.69 m) 48ft. 11in. (14.91 m)
Wheelbase	12ft. 6in. (3.81 m)
Tailswing	5ft. 6in. (1.6 m)
Ground Clearance (Axle)	12in. (30.4 cm)
Ground Clearance (Chassis)	25.5 in. (64.7 cm)

Chassis

Table 6-4. Chassis Specifications

Maximum Travel Grade With boom in stowed position (Gradeability)	45%
Maximum Travel Grade With boom in stowed position (Side Slope)	5°
Turning Radius (Axles Retracted)	
Outside	22 ft. 6 in. (6.8 m)
Inside	14 ft. 5 in. (4.4 m)
Turning Radius (Axles Extended)	
Inside	8 ft. (2.4 m)
Outside	19 ft. 4 in. (5.9 m)
Max Tire Load	
1200SJP	25,000 lbs. (11,340 kg)
1350SJP	26,250 lbs. (11,907 kg)
Max Ground Bearing Pressure	
1200SJP	100 psi (7.03 kg/cm ²)
1350SJP	105 psi (7.38 kg/cm ²)
Maximum Drive Speed	3.25 mph (5.2 kph)
Max. Hydraulic System Pressure	4600 psi (317 Bar)

Table 6-4. Chassis Specifications

Maximum Wind Speed	28 mph (12.5 m/s)
Maximum Manual Force	400 N
Electrical System Voltage	12 Volts
Gross Machine Weight (Platform Empty)	
1200SJP	41,100 lb. (18,643 kg)
1350SJP	44,750 lb. (20,298 kg)

Capacities

Table 6-5. Capacities

Hydraulic Tank	55 gallons (208 liters)
Fuel Tank	31 gallons (117 liters)
Hydraulic System	66 gallons (250 liters)

SECTION 6 - GENERAL SPECIFICATIONS & OPERATOR MAINTENANCE

Tires

Table 6-6. Tire Specifications

Size	445/50D710
Load Range	J
Ply Rating	18
Load Rating	26,500 lbs. @ 100 psi (12020 kg @ 6.9 Bar)
Foam Fill	Polyurethane HD (55 Durometer) Foam
Max Tire Load	
1200SJP	25,000 lbs. (11,340 kg)
1350SJP	26,250 lbs. (11,907 kg)

Engine Data - Deutz 2011 Prior to S/N 0300127698

Table 6-7. Deutz BF4M2011 Specifications

Type	Liquid Cooled
Number of Cylinders	4
Bore	3.7 in. (94 mm)
Stroke	4.4 in. (112 mm)
Total Displacement	190 cu. in. (3108 cm ³)
Compression Ratio	17.5:1
Firing Order	1-3-4-2
Output	87hp (65 kW)
Oil Capacity	
Cooling System	5 Quarts (4.5 L)
w/Filter	11 Quarts (10.5 L)
Total Capacity	16 Quarts (15 L)
Average Fuel Consumption	1.1 gph (4.1 lph)
Idle Engine RPM	1200
Mid Engine RPM	1800
High Engine RPM	2475

SECTION 6 - GENERAL SPECIFICATIONS & OPERATOR MAINTENANCE

Engine Data - Deutz 2011 S/N 0300127698 to Present

Table 6-8. Deutz TD2011L4 Specifications

Type	Liquid Cooled
Number of Cylinders	4
Bore	3.7 in. (94 mm)
Stroke	4.4 in. (112 mm)
Total Displacement	190 cu. in. (3108 cm ³)
Compression Ratio	17.5:1
Firing Order	1-3-4-2
Output	75hp (56 kW)
Oil Capacity	
Cooling System	5 Quarts (4.5L)
w/Filter	11 Quarts (10.5L)
Total Capacity	16 Quarts (15L)
Average Fuel Consumption	1.1 gph (4.1 lph)
Idle Engine RPM	1200
Mid Engine RPM	1800
High Engine RPM	2475

Engine Data - Deutz TCD2.9L4

Table 6-9. Deutz TCD2.9L4 Specifications

Type	Liquid Cooled
Number of Cylinders	4
Bore	3.6 in. (92 mm)
Stroke	4.3 in. (110 mm)
Total Displacement	178 cu. in. (2925 cm ³)
Firing Order	1-3-4-2
Output	74.2hp (55.4 kW)
Oil Capacity	2.4 Gallon (8.9L)
Coolant Capacity (System)	3.2Gallon (12.1 L)
Average Fuel Consumption	1.2 gph (4.1 lph)
Min. Low Engine RPM	1200
Mid Engine RPM	1800
Max. High Engine RPM	2500

SECTION 6 - GENERAL SPECIFICATIONS & OPERATOR MAINTENANCE

Engine Data - Caterpillar

Table 6-10. Caterpillar 3.4T Specifications

Type	Liquid Cooled, Antifreeze
Number of Cylinders	4
Bore	3.7 in. (94 mm)
Stroke	4.7 in. (120 mm)
Total Displacement	201 cu. in. (3294 cm ³)
Compression Ratio	19.5:1
Firing Order	1-3-4-2
Output	73.7hp (55 kW)
Oil Capacity	10.5 Quarts (10 L)
Average Fuel Consumption	1.36 gph (5.14 lph)
Idle Engine RPM	1200
Mid Engine RPM	1800
High Engine RPM	2475

Hydraulic Oil

Table 6-11. Hydraulic Oil Specifications

Hydraulic System Operating Temperature Range	S.A.E. Viscosity Grade
+0° to +180° F (-18° to +83° C)	10W
+0° to +210° F (-18° to +99° C)	10W-20, 10W30
+50° to +210° F (+10° to +99° C)	20W-20

NOTE: Hydraulic oils must have anti-wear qualities at least to API Service Classification GL-3, and sufficient chemical stability for mobile hydraulic system service. JLG Industries recommends Mobilfluid 424 hydraulic oil, which has an SAE viscosity index of 152.

NOTE: When temperatures remain consistently below 20 degrees F. (-7 degrees C.), JLG Industries recommends the use of Mobil DTE13.

Aside from JLG recommendations, it is not advisable to mix oils of different brands or types, as they may not contain the same required additives or be of comparable viscosities. If use of hydraulic oil other than Mobilfluid 424 is desired, contact JLG Industries for proper recommendations.

SECTION 6 - GENERAL SPECIFICATIONS & OPERATOR MAINTENANCE

Table 6-12. Mobilfluid 424 Specs

SAE Grade	10W30
Gravity, API	29.0
Density, Lb/Gal. 60°F	7.35
Pour Point, Max	-46°F (-43°C)
Flash Point, Min.	442°F (228°C)
Viscosity	
Brookfield, cP at -18°C	2700
at 40°C	55 cSt
at 100°C	9.3 cSt
Viscosity Index	152

Table 6-13. Mobil DTE 13M Specs

ISO Viscosity Grade	#32
Specific Gravity	0.877
Pour Point, Max	-40°F (-40°C)
Flash Point, Min.	330°F (166°C)
Viscosity	
at 40°C	33cSt
at 100°C	6.6 cSt
at 100°F	169SUS
at 210°F	48SUS
cp at -20°F	6,200
Viscosity Index	140

SECTION 6 - GENERAL SPECIFICATIONS & OPERATOR MAINTENANCE

Table 6-14. UCon Hydrolube HP-5046

Type	Synthetic Biodegradable
Specific Gravity	1.082
Pour Point, Max	-58°F (-50°C)
pH	9.1
Viscosity	
at 0°C (32°F)	340 cSt (1600SUS)
at 40°C (104°F)	46 cSt (215SUS)
at 65°C (150°F)	22 cSt (106SUS)
Viscosity Index	170

Table 6-15. Mobil EAL H 46 Specs

Type	Synthetic Biodegradable
ISO Viscosity Grade	46
Specific Gravity	.910
Pour Point	-44°F (-42°C)
Flash Point	500°F (260°C)
Operating Temp.	0 to 180°F (-17 to 162°C)
Weight	7.64 lb. per gal. (0.9 kg per liter)
Viscosity	
at 40°C	45 cSt
at 100°C	8.0 cSt
Viscosity Index	153

Table 6-16. Exxon Unavis HVI 26 Specs

Specific Gravity	32.1
Pour Point	-76°F (-60°C)
Flash Point	217°F (103°C)
Viscosity	
at 40°C	25.8 cSt
at 100°C	9.3 cSt
Viscosity Index	376
NOTE: <i>Mobil/Exxon recommends that this oil be checked on a yearly basis for viscosity.</i>	

SECTION 6 - GENERAL SPECIFICATIONS & OPERATOR MAINTENANCE

Major Component Weights

Table 6-17. Component Weights

Component	Pounds	Kilograms
Tire & Wheel	867	393
Drive Hub & Motor	275.5	123
Swing Drive	290	132
Engine Assembly	1275	579
1350 Boom (Complete)	11850	5375
1200 Boom (Complete)	11100	5035
Lift Cylinder	787	357
1350 Tele Cylinder	1322	600
1200 Tele Cylinder	1170	531
Jib Cylinder	69	31
Axle Oscillation Cylinder	74	34
Axle Extend Cylinder	92	42
Level Cylinder	89	40
Platform 36 x 96	245	111
Platform 36 x 72	195	89
1350 Counterweight	8500	3856

Table 6-17. Component Weights

Component	Pounds	Kilograms
1200 Counterweight	5494	2492
T/T Assy. (less Cwt)	9450	4286

SECTION 6 - GENERAL SPECIFICATIONS & OPERATOR MAINTENANCE

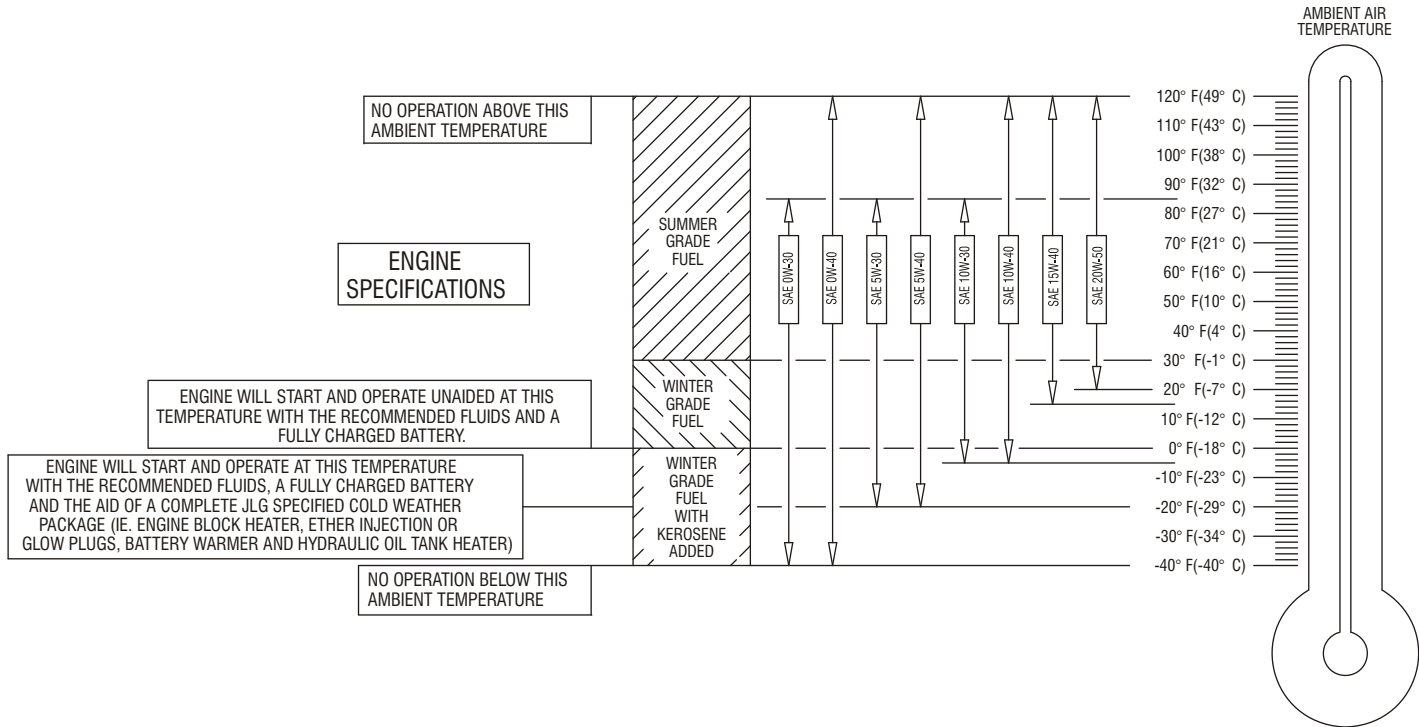

Figure 6-1. Engine Operating Temperature Specifications - Deutz - Sheet 1 of 2

SECTION 6 - GENERAL SPECIFICATIONS & OPERATOR MAINTENANCE

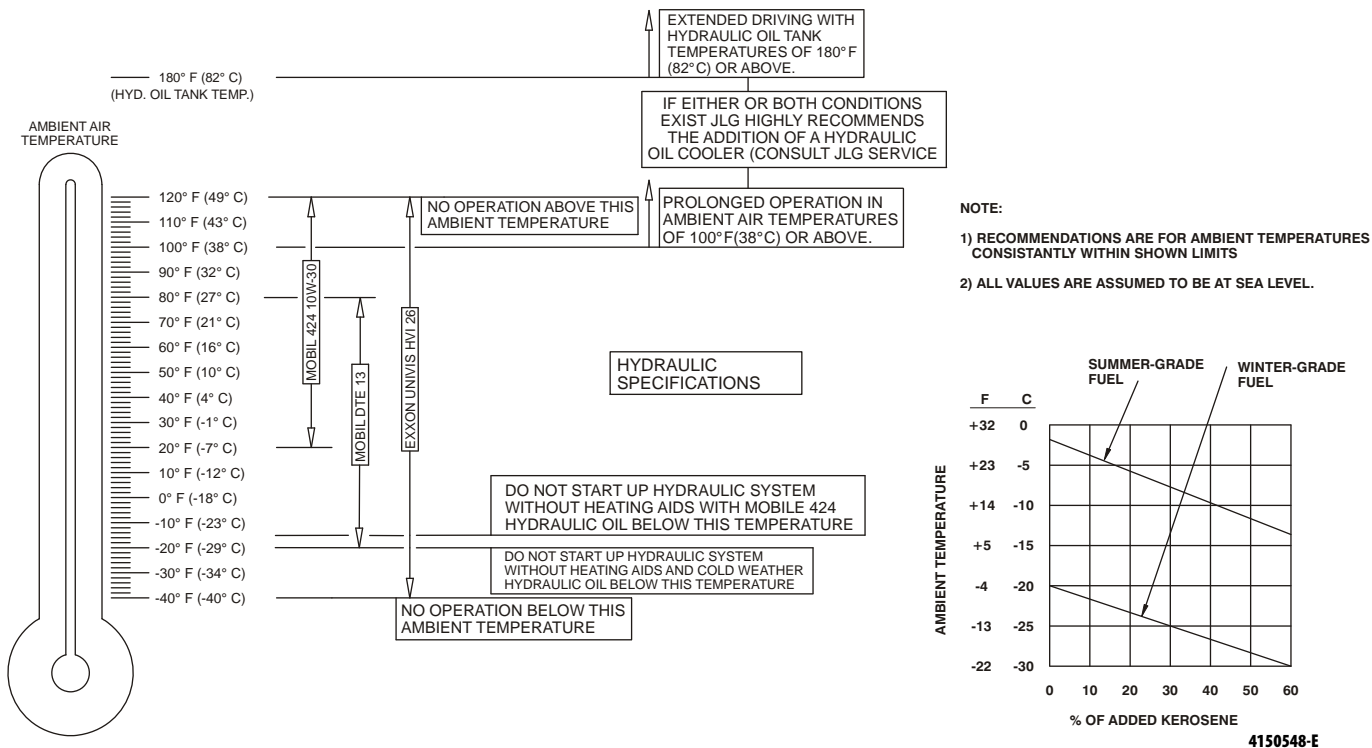

Figure 6-2. Engine Operating Temperature Specifications - Deutz - Sheet 2 of 2

4150548-E

SECTION 6 - GENERAL SPECIFICATIONS & OPERATOR MAINTENANCE

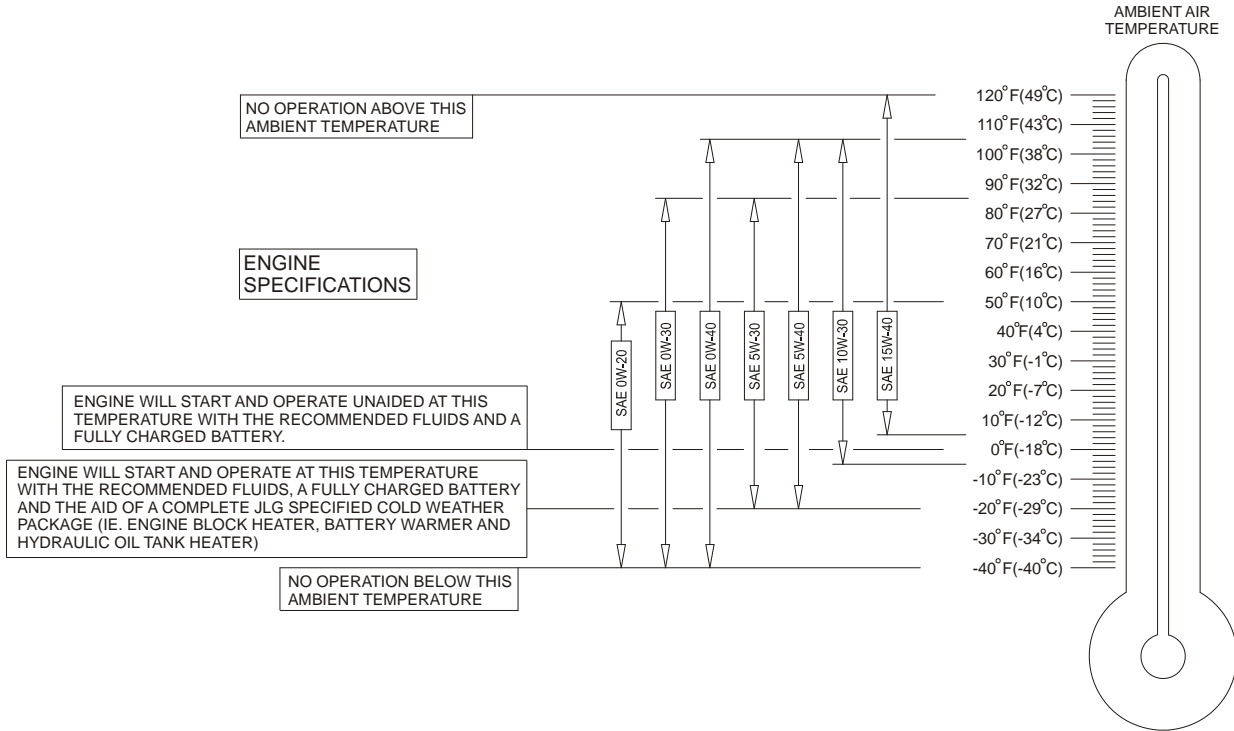
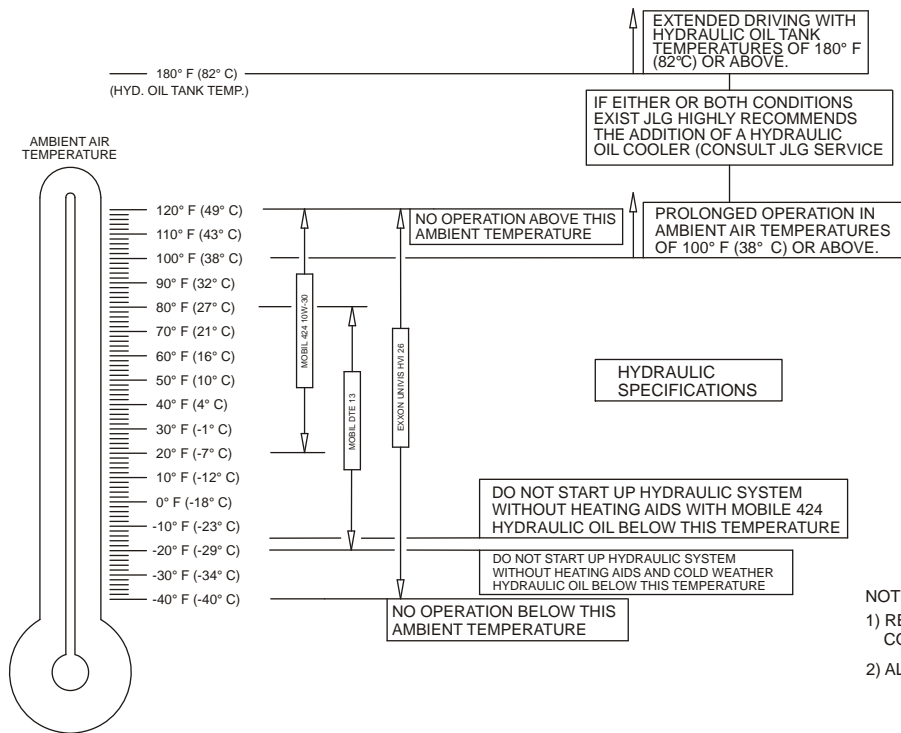

Figure 6-3. Engine Operating Temperature Specifications - Caterpillar - Sheet 1 of 2

SECTION 6 - GENERAL SPECIFICATIONS & OPERATOR MAINTENANCE



NOTE:

- 1) RECOMMENDATIONS ARE FOR AMBIENT TEMPERATURES CONSISTENTLY WITHIN SHOWN LIMITS
- 2) ALL VALUES ARE ASSUMED TO BE AT SEA LEVEL.

Figure 6-4. Engine Operating Temperature Specifications - Caterpillar - Sheet 2 of 2

4150548-E

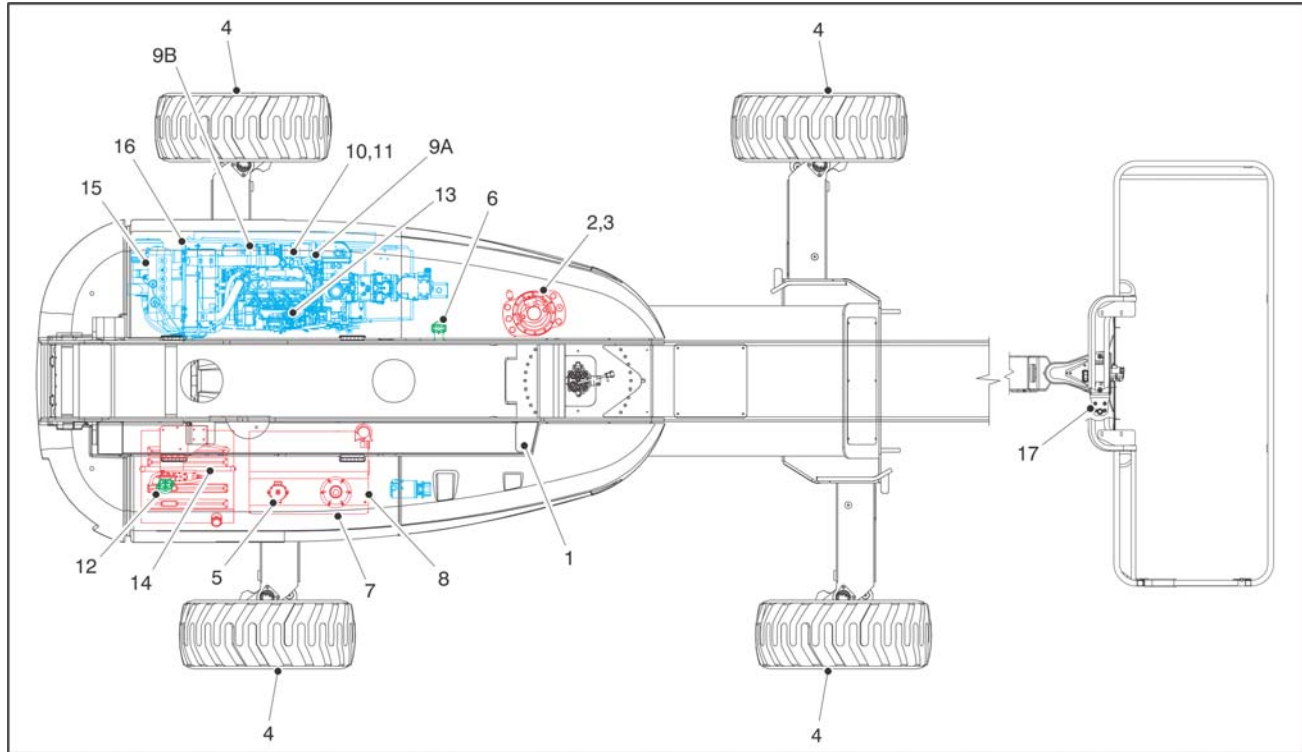

Figure 6-5. Lubrication and Maintenance Point Location

SECTION 6 - GENERAL SPECIFICATIONS & OPERATOR MAINTENANCE

6.3 OPERATOR MAINTENANCE

NOTE: The following numbers correspond to those in Figure 6-5., Lubrication and Maintenance Point Location.

Table 6-18. Lubrication Specifications

KEY	SPECIFICATIONS
MPG	Multipurpose Grease having a minimum dripping point of 350°F (177°C). Excellent water resistance and adhesive qualities, and being of extreme pressure type. (Timken OK 40 pounds minimum.)
EPGL	Extreme Pressure Gear Lube (oil) meeting API service classification GL-5 or MIL-Spec MIL-L-2105
HO	Hydraulic Oil. API service classification GL-3, e.g. Mobilfluid 424.
EO	Engine (crankcase) Oil. Gas - API SF, SH, SG class, MIL-L-2104. Diesel - API CC/CD class, MIL-L-2104B/MIL-L-2104C.

NOTICE

LUBRICATION INTERVALS ARE BASED ON MACHINE OPERATION UNDER NORMAL CONDITIONS. FOR MACHINES USED IN MULTI-SHIFT OPERATIONS AND/OR EXPOSED TO HOSTILE ENVIRONMENTS OR CONDITIONS, LUBRICATION FREQUENCIES MUST BE INCREASED ACCORDINGLY.

NOTE: It is recommended as a good practice to replace all filters at the same time.

1. Swing Bearing - Remote Lube



Lube Point(s) - 2 Grease Fitting

Capacity - A/R

Lube - MPG

Interval - Every 3 months or 150 hours of operation

2. Swing Gearbox

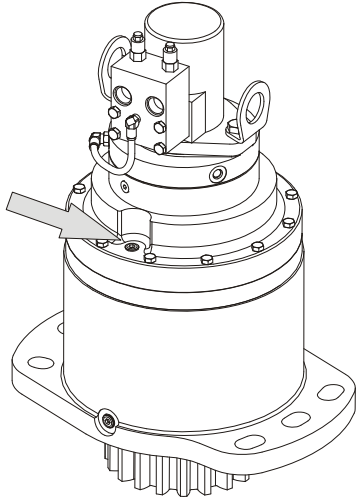

Lube Point(s) - Fill Plug
Capacity - 79 ounces (2.3 L)
Lube - GL-5
Interval - Check level every 150 hrs/Change every 1200 hours of operation. Fill to cover ring gear.

3. Swing Brake

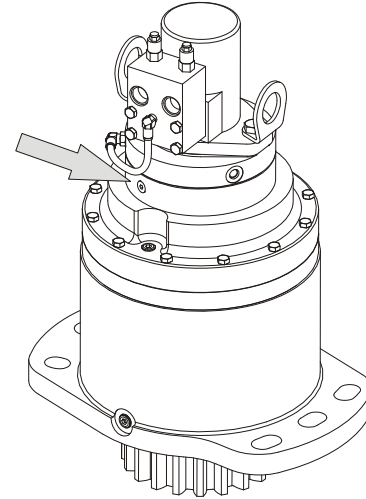

Lube Point(s) - Fill Plug
Capacity - 2.7 ounces (80 ml)
Lube - DTE24
Interval - Check level every 150 hrs/Change every 1200 hours of operation.

SECTION 6 - GENERAL SPECIFICATIONS & OPERATOR MAINTENANCE

NOTE: After S/N 0300134389 machines may be built with either Bonfiglioli or Reggiana Riduttori wheel drive hubs.

4. A. Wheel Drive Hub (Prior to S/N 100131)



Lube Point(s) - Level/Fill Plug

Capacity - 0.5 liters (1/2 full)

Lube - EPGL

Interval - Change after first 150 hours then every 1200 hours of operation

B: Wheel Drive Hub (S/N 100131 to Present)

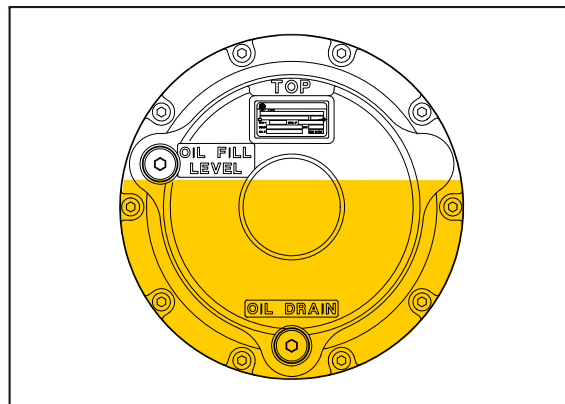

Lube Point(s) - Level/Fill Plug

Capacity - 2.1 quarts (2 liters) \pm 10%

Lube - EPGL

Interval - Change after first 150 hours then every 1200 hours of operation

Comments - Place Fill port at 12 o'clock position and Check port at 8 o'clock position. Pour lubricant into fill port until it just starts to flow out of check port.

SECTION 6 - GENERAL SPECIFICATIONS & OPERATOR MAINTENANCE

C: Wheel Drive Hub - Reggiana Riduttori (S/N 134389 to Present)



Lube Point(s) - Level/Fill Plug

Capacity - 0.5 quarts (0.5 liters) \pm 10%

Lube - EPGL

Interval - Change after first 150 hours then every 1200 hours of operation

Comments - Place Fill port at 12 o'clock position and Check port at 3 o'clock position. Pour lubricant into fill port until it just starts to flow out of check port.

5. Hydraulic Return Filter



Lube Point(s) - Replaceable Element

Interval - Change after first 50 hours and every 300 hours thereafter or as indicated by condition indicator

6. Hydraulic Charge Filter

Lube Point(s) - Replaceable Element

Interval - Change after first 50 hours and every 300 hours thereafter or as indicated by condition indicator.

SECTION 6 - GENERAL SPECIFICATIONS & OPERATOR MAINTENANCE

7. Hydraulic Oil

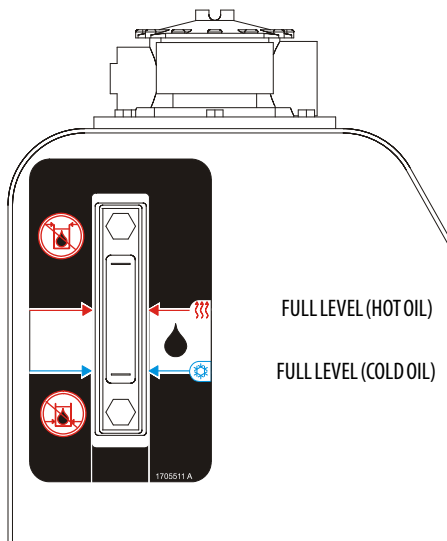

Lube Point(s) - Fill Cap

Capacity - 55 gallons (208 liters) Tank

Lube - HO

Interval - Check level daily. Change every 2 years or 1200 hours of operation.

8. Suction Strainers (In Tank)

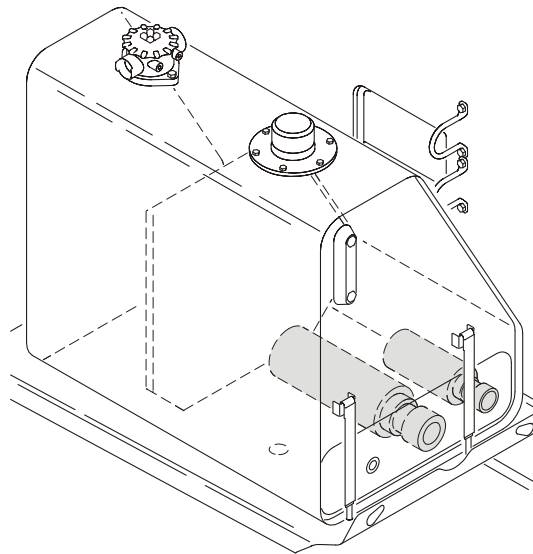

Lube Point(s) - 2

Interval - Every 2 years or 1200 hours of operation.

Remove and clean at time of hydraulic oil change.

SECTION 6 - GENERAL SPECIFICATIONS & OPERATOR MAINTENANCE

9. A. Oil Change w/Filter - Deutz 2011



Lube Point(s) - Fill Cap/Spin-on Element

Capacity -

5 Quarts (4.5 L) Cooling System

11 Quarts (10.5 L) w/Filter

16 Quarts (15 L) Total Capacity

Lube - EO

Interval - Check level daily; change every 500 hours or six months, whichever comes first. Adjust final oil level by mark on dipstick.

B. Oil Change w/Filter - Deutz TCD2.9



Lube Point(s) - Fill Cap/Spin-on Element

Capacity - 2.4 Gallon (8.9 L)

Lube - EO

Interval - Check level daily; change every 500 hours or six months, whichever comes first. Adjust final oil level by mark on dipstick.

SECTION 6 - GENERAL SPECIFICATIONS & OPERATOR MAINTENANCE

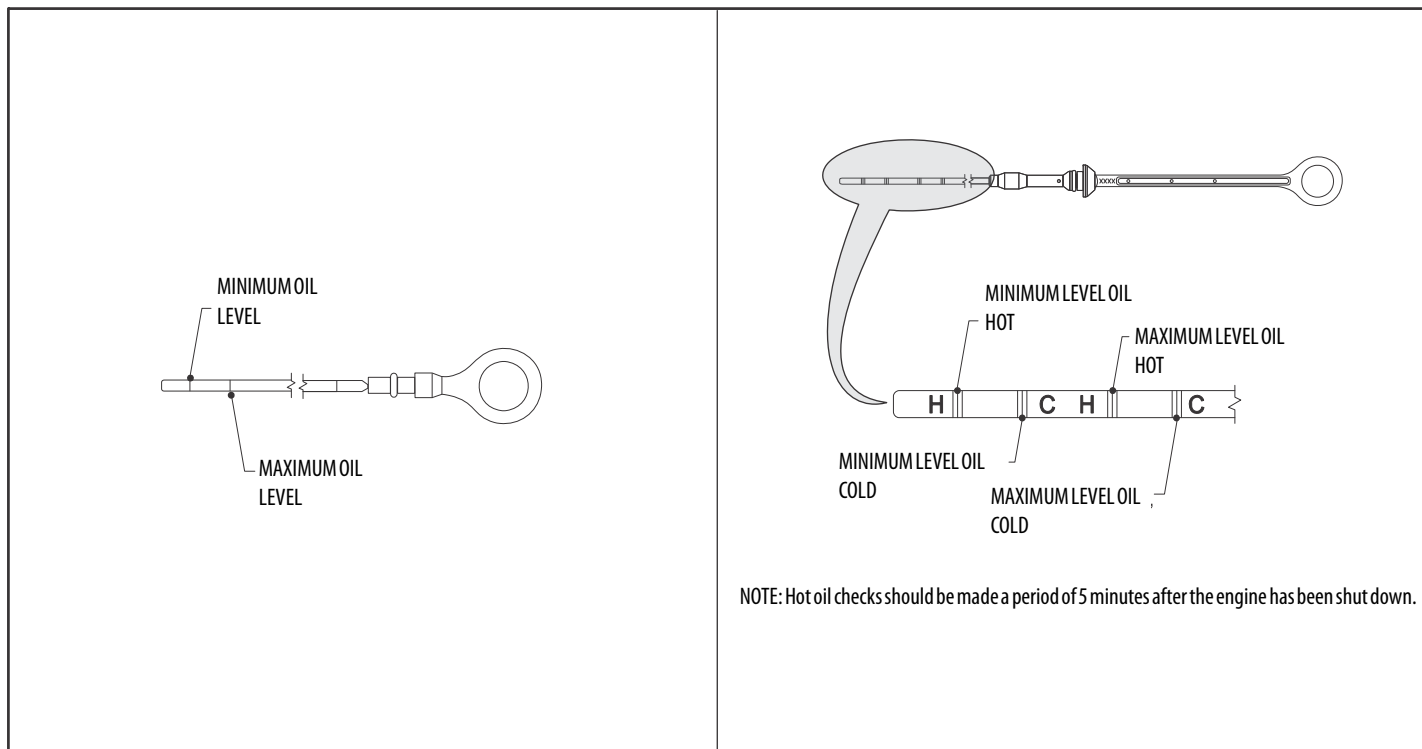

Figure 6-6. Deutz 2011 Engine Dipstick

SECTION 6 - GENERAL SPECIFICATIONS & OPERATOR MAINTENANCE

10. A. Fuel Filter - Deutz 2011



Lube Point(s) - Replaceable Element
Interval - Every year or 600 hours of operation

B. Fuel Filter - Deutz TCD2.9



Lube Point(s) - Replaceable Element
Interval - Every year or 600 hours of operation

SECTION 6 - GENERAL SPECIFICATIONS & OPERATOR MAINTENANCE

11. Fuel Strainer -Deutz 2011

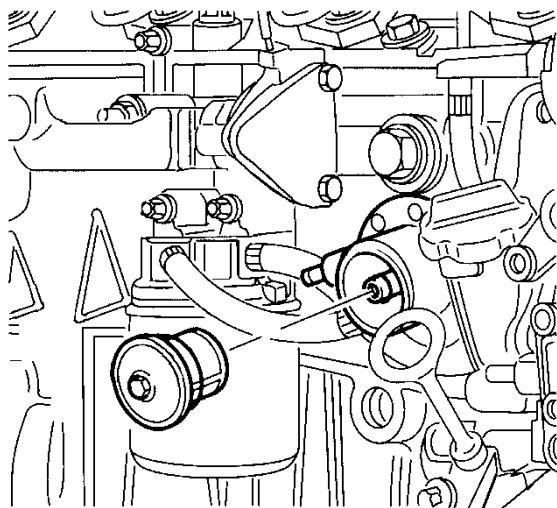

Lube Point(s) - Replaceable Element
Interval - Every year or 600 hours of operation

12. Fuel Pre-Filter TCD2.9



Lube Point(s) - Replaceable Element
Interval - Drain water daily; Change every year or 600 hours of operation

13. Oil Change w/Filter - CAT

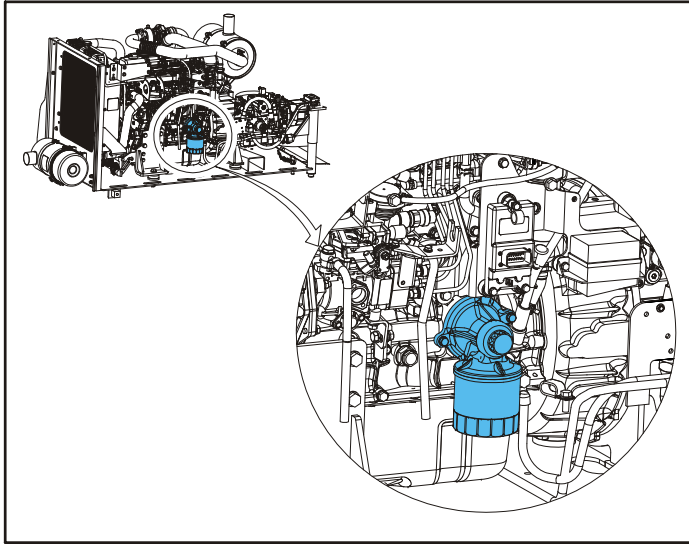

Lube Point(s) - Fill Cap/Spin-on Element

Capacity - 10.5 Quarts (10 L)

Lube - EO

Interval - Check level daily; change every 150 hours or three months, whichever comes first. Adjust final oil level by mark on dipstick.

14. Fuel Filter - CAT

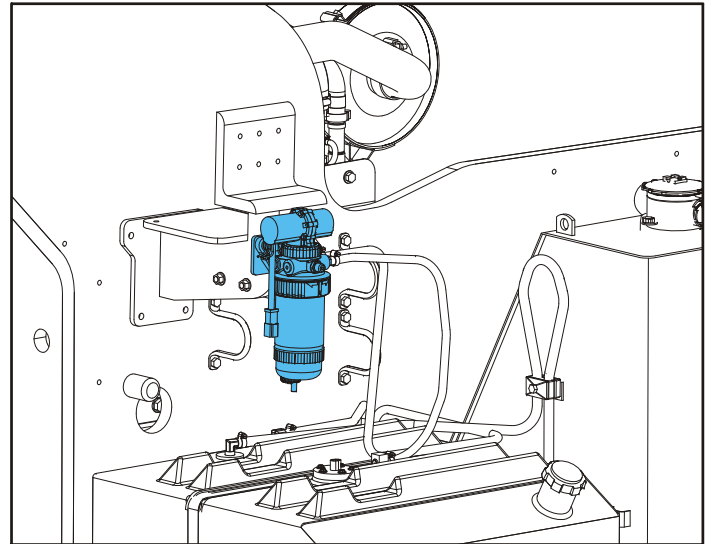

Lube Point(s) - Replaceable Element

Interval - Every year or 600 hours of operation

SECTION 6 - GENERAL SPECIFICATIONS & OPERATOR MAINTENANCE

15. Radiator Coolant TCD2.9

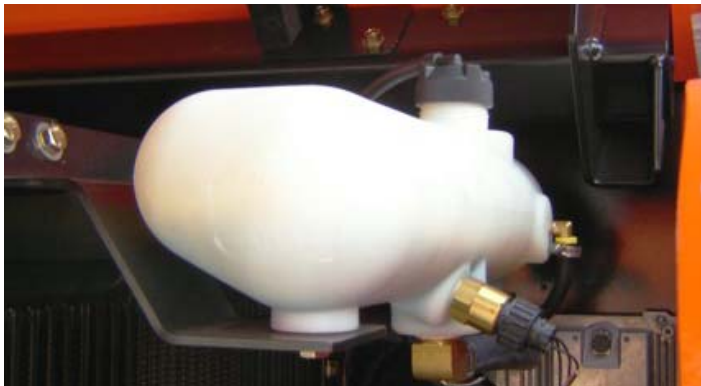

Lube Point(s) - Fill Cap
Capacity - 3.2Gallon (12.1 L)
Lube - Anti-Freeze
Interval - Check level daily; change every 1000 hours or 2 years, whichever comes first.

16. A. Air Filter - Deutz 2011



Lube Point(s) - Replaceable Element
Interval - Every 6 months or 300 hours of operation or as indicated by the condition indicator

SECTION 6 - GENERAL SPECIFICATIONS & OPERATOR MAINTENANCE

B. Air Filter - Deutz TCD2.9



Lube Point(s) - Replaceable Element

Interval - Every 6 months or 300 hours of operation or as indicated by the condition indicator

Comments - Check Dust Valve daily

17. Platform Filter



Lube Point(s) - Replaceable Element

Interval - Change after first 50 hours and then every year or 600 hours of operation thereafter

6.4 TIRES & WHEELS

Tire Inflation

The air pressure for pneumatic tires must be equal to the air pressure that is stenciled on the side of the JLG product or rim decal for safe and proper operational characteristics.

Tire Damage

For pneumatic tires, JLG Industries, Inc. recommends that when any cut, rip, or tear is discovered that exposes sidewall or tread area cords in the tire, measures must be taken to remove the JLG product from service immediately. Arrangements must be made for replacement of the tire or tire assembly.

For polyurethane foam filled tires, JLG Industries, Inc. recommends that when any of the following are discovered, measures must be taken to remove the JLG product from service immediately and arrangements must be made for replacement of the tire or tire assembly.

- a smooth, even cut through the cord plies which exceeds 3 inches (7.5 cm) in total length
- any tears or rips (ragged edges) in the cord plies which exceeds 1 inch (2.5 cm) in any direction
- any punctures which exceed 1 inch in diameter

- any damage to the bead area cords of the tire

If a tire is damaged but is within the above noted criteria, the tire must be inspected on a daily basis to insure the damage has not propagated beyond the allowable criteria.

Tire Replacement

JLG recommends a replacement tire be the same size, ply and brand as originally installed on the machine. Please refer to the JLG Parts Manual for the part number of the approved tires for a particular machine model. If not using a JLG approved replacement tire, we recommend that replacement tires have the following characteristics:

- Equal or greater ply/load rating and size of original
- Tire tread contact width equal or greater than original
- Wheel diameter, width, and offset dimensions equal to the original
- Approved for the application by the tire manufacturer (including inflation pressure and maximum tire load)

Unless specifically approved by JLG Industries Inc. do not replace a foam filled or ballast filled tire assembly with a pneumatic tire. When selecting and installing a replacement tire, ensure that all tires are inflated to the pressure recommended by JLG. Due to size variations between tire brands, both tires on the same axle should be the same.

Wheel Replacement

The rims installed on each product model have been designed for stability requirements which consist of track width, tire pressure, and load capacity. Size changes such as rim width, center piece location, larger or smaller diameter, etc., without written factory recommendations, may result in an unsafe condition regarding stability.

Wheel Installation

It is extremely important to apply and maintain proper wheel mounting torque.

⚠ WARNING

WHEEL NUTS MUST BE INSTALLED AND MAINTAINED AT THE PROPER TORQUE TO PREVENT LOOSE WHEELS, BROKEN STUDS, AND POSSIBLE DANGEROUS SEPARATION OF WHEEL FROM THE AXLE. BE SURE TO USE ONLY THE NUTS MATCHED TO THE CONE ANGLE OF THE WHEEL.

Tighten the lug nuts to the proper torque to prevent wheels from coming loose. Use a torque wrench to tighten the fasteners. If you do not have a torque wrench, tighten the fasteners with a lug wrench, then immediately have a service garage or dealer tighten the lug nuts to the proper torque. Over-tightening will result in breaking the studs or permanently deforming the mounting stud holes in the wheels. The proper procedure for attaching wheels is as follows:

1. Start all nuts by hand to prevent cross threading. DO NOT use a lubricant on threads or nuts.
2. Tighten nuts in the following sequence:

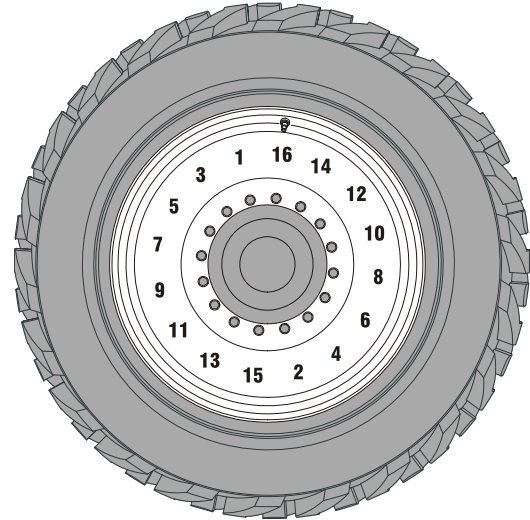

3. The tightening of the nuts should be done in stages. Following the recommended sequence, tighten nuts per wheel torque chart.

Table 6-19. Wheel Torque Chart

TORQUE SEQUENCE		
1st Stage	2nd Stage	3rd Stage
45 ft. lbs. (60 Nm)	100 ft. lbs. (140 Nm)	180 ft. lbs. (252 Nm)

4. Wheel nuts should be torqued before first road use and after each wheel removal. Check and torque every 3 months or 150 hours of operation.

6.5 SUPPLEMENTAL INFORMATION

The following information is provided in accordance with the requirements of the European Machinery Directive 2006/42/EC and is only applicable to CE machines.

For electric powered machines, the equivalent continuous A-Weighted sound pressure level at the work platform is less than 70dB(A)

For combustion engine powered machines, guaranteed Sound Power Level (LWA) per European Directive 2000/14/EC (Noise Emission in the Environment by Equipment for Use Outdoors) based on test methods in accordance with Annex III, Part B, Method 1 and 0 of the directive, is 106 dB.

The vibration total value to which the hand-arm system is subjected does not exceed $2,5 \text{ m/s}^2$. The highest root mean square value of weighted acceleration to which the whole body is subjected does not exceed $0,5 \text{ m/s}^2$.

SECTION 7. INSPECTION AND REPAIR LOG

Machine Serial Number _____

Table 7-1. Inspection and Repair Log

Date	Comments

SECTION 7 - INSPECTION AND REPAIR LOG

Table 7-1. Inspection and Repair Log

Date	Comments



An Oshkosh Corporation Company

TRANSFER OF OWNERSHIP

To Product Owner:

If you now own but ARE NOT the original purchaser of the product covered by this manual, we would like to know who you are. For the purpose of receiving safety-related bulletins, it is very important to keep JLG Industries, Inc. updated with the current ownership of all JLG products. JLG maintains owner information for each JLG product and uses this information in cases where owner notification is necessary.

Please use this form to provide JLG with updated information with regard to the current ownership of JLG products. Please return completed form to the JLG Product Safety & Reliability Department via facsimile or mail to address as specified below.

Thank You,
Product Safety & Reliability Department
JLG Industries, Inc.
13224 Fountainhead Plaza
Hagerstown, MD 21742
USA
Telephone: +1-717-485-6591
Fax: +1-301-745-3713

NOTE: Leased or rented units should not be included on this form.

Mfg. Model: _____

Serial Number: _____

Previous Owner: _____

Address: _____

Country: _____ Telephone: (____) _____

Date of Transfer: _____

Current Owner: _____

Address: _____

Country: _____ Telephone: (____) _____

Who in your organization should we notify?

Name: _____

Title: _____



WARNING:



The engine exhaust from this product contains chemicals known to the State of California to cause cancer, birth defects, or other reproductive harm.

1702961

PROPOSITION 65 WARNING

- **Battery posts, terminals and related accessories contain lead and lead compounds, chemicals known to the State of California to cause cancer and reproductive harm.**
- **Batteries also contain other chemicals known to the State of California to cause cancer.**
- **Wash hands after handling.**



An Oshkosh Corporation Company

Corporate Office
JLG Industries, Inc.
1 JLG Drive
McConnellsburg PA. 17233-9533
USA

(717) 485-5161

(717) 485-6417



3121141

JLG Worldwide Locations

JLG Industries (Australia)

P.O. Box 5119
11 Bolwarra Road
Port Macquarie
N.S.W. 2444
Australia

+61 2 65 811111

+61 2 65813058

JLG Latino Americana Ltda.

Rua Eng. Carlos Stevenson,
80-Suite 71
13092-310 Campinas-SP
Brazil

+55 19 3295 0407

+55 19 3295 1025

JLG Industries (UK) Ltd

Bentley House
Bentley Avenue
Middleton

Greater Manchester
M24 2GP - England

+44 (0)161 654 1000

+44 (0)161 654 1001

JLG France SAS

Z.I. de Baulieu
47400 Fauillet
France

+33 (0)5 53 88 31 70

+33 (0)5 53 88 31 79

JLG Deutschland GmbH

Max-Planck-Str. 21
D - 27721 Ritterhude - Ihlpohl
Germany

+49 (0)421 69 350 20

+49 (0)421 69 350 45

JLG Equipment Services Ltd.

Rm 1107 Landmark North
39 Lung Sum Avenue
Sheung Shui N. T.
Hong Kong

(852) 2639 5783

(852) 2639 5797

JLG Industries (Italia) s.r.l.

Via Po. 22
20010 Pregnana Milanese - MI
Italy

+39 029 359 5210

+39 029 359 5845

Oshkosh-JLG Singapore Technology

Equipment Pte Ltd
29 Tuas Ave 4,
Jurong Industrial Estate
Singapore, 639379

+65-6591 9030

+65-6591 9031

Oshkosh-JLG (Tianjin) Equipment

Technology, Ltd
Pudong Kerry Parkside
Room 3705
1155 Fang Dian Road
Pudong, Shanghai 201204

+0086 21 60311575

+0086 21 60311599

Plataformas Elevadoras

JLG Iberica, S.L.
Trapadella, 2
P.I. Castellbisbal Sur
08755 Castellbisbal, Barcelona
Spain

+34 93 772 4700

+34 93 771 1762

JLG Sverige AB

Enkopingsvagen 150
Box 704
SE - 176 27 Jarfalla
Sweden

+46 (0)850 659 500

+46 (0)850 659 534